



English

VISION:mini™
22mm cubic VGA
PoCL-Lite B/W CMOS Camera

VCC-GC10V31L

Product Specification
& Operational Manual

CIS Corporation

Table of Contents

1. Scope of Application.....	3
2. Handling Precautions	3
3. Product Outline.....	4
4. Specification.....	5
4.1. General Specification	5
4.2. Camera Output Signal Specification.....	7
4.3. CCD Spectral Response (Representative value).....	7
5. Function Settings.....	8
6. External Connector Pin Assignment	9
7. Timing Chart.....	10
7.1. Horizontal Synchronous Signal Timing.....	10
7.2. Vertical Synchronous Signal Timing.....	10
7.2.1. Full Frame Scan Mode.....	10
7.2.2. Partial Scan Mode.....	11
7.3. Fixed Trigger Shutter Mode	12
7.4. Pulse Width Trigger Shutter Mode.....	13
8. Remote Interface Function	14
9. Initial Settings	15
10. CCD Optical Axis Accuracy	16
11. Dimensions.....	17
12. Cases for Indemnity (Limited Warranty).....	18
13. Sensor Pixel Defect	19
14. Product Support.....	19

1. Scope of Application

This is to describe VCC-GC10V31L, Power over Camera Link-Lite B/W CMOS Camera. All specifications contained herein are subject to change without prior notice. Reproduction in whole or in part is prohibited.

2. Handling Precautions

The camera must not be used for any nuclear equipments or aerospace equipments with which mechanical failure or malfunction could result in serious bodily injury or loss of human life. Our warranty does not apply to damages or defects caused by irregular and/or abnormal use of the product.

Please observe all warnings and cautions stated below.

Our warranty does not apply to damages or malfunctions caused by neglecting these precautions.

- Do not use or store the camera in the following extreme conditions:
 - Extremely dusty or humid places.
 - Extremely hot or cold places (operating temperature -5°C to $+45^{\circ}\text{C}$)
 - Close to generators of powerful electromagnetic radiation such as radio or TV transmitters.
 - Places subject to fluorescent light reflections.
 - Places subject to unstable (flickering, etc.) lighting conditions.
 - Places subject to strong vibration.
- Remove dust or dirt on the surface of the lens with a blower.
- Do not apply excessive force or static electricity that could damage the camera.
- Do not shoot direct images that are extremely bright (e.g., light source, sun, etc.), and when camera is not in use, put the lens cap on.
- Follow the instructions typeapter 6, "External connector pin assignment" for connecting the camera. Improper connection may cause damages not only to the camera but also to the connected devices.
- Confirm the mutual ground potential carefully and then connect the camera to monitors or computers. AC leaks from the connected devices may cause damages or destroy the camera.
- Do not apply excessive voltage. (Use only the specified voltage.) Unstable or improper power supply voltage may cause damages or malfunction of the camera.
- The voltage ripple of camera power DC $+12\text{V} \pm 10\%$ shall be within $\pm 50\text{mV}$. Improper power supply voltage may cause noises on the video signals.

In case of abnormal operation, contact the distributor from whom you purchased the product.

3. Product Outline

VCC-GC10V31L is an industrial B/W digital video camera module utilizing a 1/3 type, global shutter type, CMOS. At Full Frame Scan Mode, entire pixels can be read out within approx. 1/60s. Interface of GC10V31L complies with a camera link standard, (the one to be determined as PoCL-Lite).

Key Features

- PoCL-Lite Camera.
- Only 22mm cubic in size (excluding projection), light weight 19g, and speed makes it a best match for use in embedded systems.
- Only 0.65W with power consumption.
- Camera settings can be changed via serial communications.
- OFF ~ 1/30,000s shutter speed can be set with fixed trigger.
- OFF ~ 1/40,000s shutter speed can be set with pulse width trigger.
- Full frame scan mode and three partial scan modes can be set.

Optional accessory

- NF – C mount Adaptor Ring

4. Specification

4.1. General Specification

Item	Specification		
Pickup device	Device Type	1/3 type B/W CMOS, Aptina MT9V0241A7XTM	
	Effective Pixel Number	752(H) x 480 (V)	
	Unit Cell Size	6.0 μ m (H) x 6.0 μ m (V)	
	Chip Size	4.51mm (H) x 2.88mm (V)	
Video output frequency	Pixel Clock	24.5454 MHz	
	Horizontal Frequency	31.468 kHz Pixel Clock: 780 CLK	
	Vertical Frequency	Full Frame Scan Mode:	480H, 59.94 Hz
		1/2Partial Scan Mode:	240H, 120.11 Hz
		1/4Partial Scan Mode:	120H, 240.22 Hz
1/6Partial Scan Mode:		80H, approx 361.71 Hz	
Sync. system	Internal Sync. System		
Video output standard	Camera Link		
Resolution	480 TV lines		
Resolving power	10bit		
Sensitivity	F5.6 400 lx (Shutter 1/60s, Gain 0dB)		
Minimum illumination	F1.4 1 lx (Shutter 1/60s, Gain +12dB)		
Dust or stains in optical system	No dust or stain shall be detected on the testing screen with setting the camera aperture at F16.		
Power requirements	DC +12V \pm 10%		
Power consumption	0.65 W (DC +12V IN)		
Dimension	Refer to overall dimension drawing (Clause 11) 22mm x 22mm x 22mm (excluding projection)		
Mass	Approx. 19 g		
Lens mount	NF mount (Refer to overall dimension drawing)		
Optical axis accuracy	Refer to drawing for CCD Optical Axis Accuracy (Clause 10)		
Gain variable range	0 ~ +12dB (Guaranteed range)		
Gamma	1 (Fixed)		
Shutter speed variable range	Fixed Shutter: 1/60(OFF), 1/120, 1/250, 1/500, 1/1,000, 1/2,000, 1/4,000, 1/10,000, 1/30,000s Pulse Width Shutter: 1/2,000 ~ 1/40,000s Manual Shutter: 1/60(OFF) ~ 1/30,000s		
Trigger shutter mode	• Standard Trigger Shutter Mode • Pulse Width Trigger Shutter Mode		

Item	Specification		
Safety/Quality standards	UL: Conform to UL Standard including materials and others. RoHS: Conform to RoHS CE: Emission: EN55022: 2006 (Class B) Immunity: EN61000-6-2: 2005 FCC: FCC Class A Digital Device This device complies with Part 15 of FCC Rules. Operation is subject to the following two conditions: (1) this device may not cause harmful interference, and (2) this device must accept any interference received, including interference that may cause undesired operation.		
Durability	Vibration	Acceleration	98 m/s ² (10.0G)
		Frequency	20~200 Hz
		Direction	XYZ 3 directions
		Testing time	120 min for each direction
	Shock	No malfunction shall be occurred with 490m/s ² (100G) for ±X, ±Y, and ±Z, 6 directions. (without package)	
Operation environment	Temperature	Operation guaranteed: -5°C~+45°C Performance guaranteed: 0°C~+40°C	
	Humidity	RH 20~80% with no condensation	
Storage environment	Temperature	-25°C ~ +60°C	
	Humidity	RH 20~80% with no condensation	

4.2. Camera Output Signal Specification

Item		Specification	
Video output data	Video out	648 (H) x 480 (V)	At Full Frame Scan Mode
	Sync. Signal I/O	LVAL output	LVDS
Trigger input	FVAL output	LVDS	Camera Link connector
	DVAL output	LVDS	
	HD/VD input	None	
Serial Communication	Polarity	POSI/NEGA	Selectable
	Pulse width	22ms	~ 500 μ s
	Camera Link input	LVDS: CC1 input	
Video output signal	SerTC	LVDS	
	SerTFG	LVDS	
	White Clip Level	Digital 10bit	: 3FEh
	Setup Level	Digital 10bit	: 08 \pm 0h
	Dark Shading	Digital 10bit	: Under 1Ch for both horizontal and vertical

5 seconds shall be waited after turning on power to get proper camera operation.

4.3. CCD Spectral Response (Representative value)

※ Lens characteristics and illuminant characteristics are not considered.

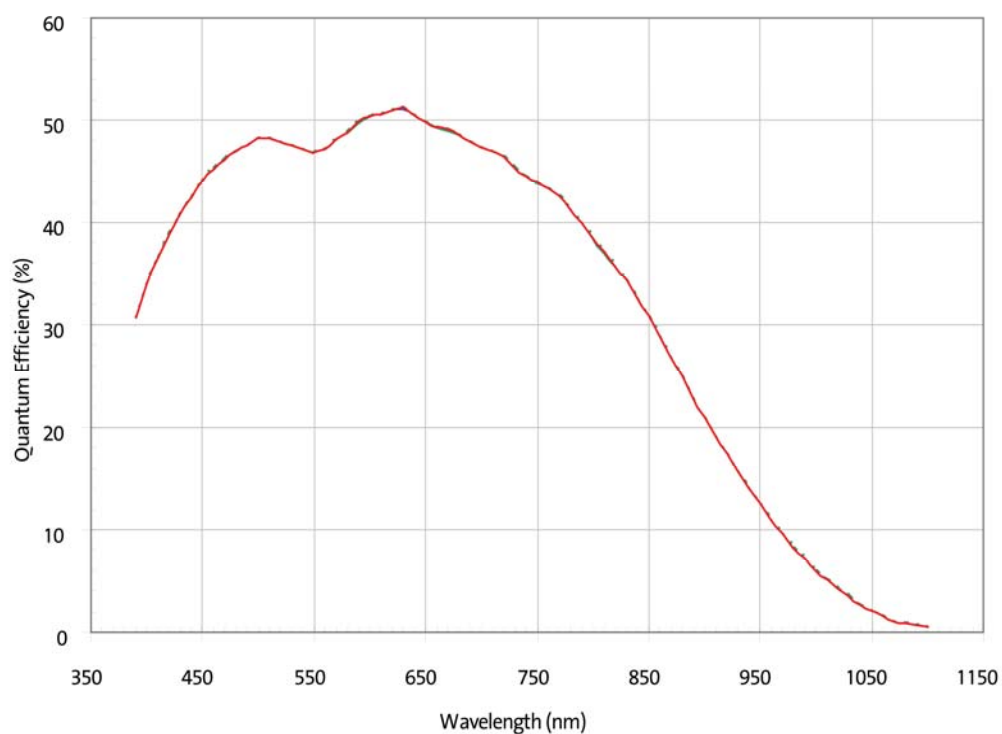

5. Function Settings

Camera functions can be set with serial data communications.

Function	Address	Data
Gain	001	0: 0 dB 1: + 6 dB 2: + 12 dB 3: Manual Gain (Refer to address 008.)
E-Shutter	002	0: 1/60s(OFF) : 522 H (Line numbers for exposure time) 1: 1/120s : 262 H 2: 1/250s : 126 H 3: 1/500s : 63 H 4: 1/1000s : 32 H 5: 1/2000s : 16 H 6: 1/4000s : 8 H 7: 1/10000s : 3 H 8: 1/30000s : 1 H 16: Manual Shutter (Refer to address 009&010.)
Trigger Shutter Mode	004	0: Normal Shutter Mode (Trigger OFF) 1: Fixed Trigger Shutter Mode (Shutter speed can be set with address 002.) 2: Pulse Width Trigger Shutter Mode (Shutter speed can be set with trigger pulse width.)
Scan Mode	005	0: Full Frame Scan Mode 1: 1/2 Partial Scan Mode (Effective are lines: 121~360) 2: 1/4 Partial Scan Mode (Effective are lines: 181~300) 3: 1/6 Partial Scan Mode (Effective are lines: 200~280) 4: 1/2 Partial Scan Manual Start Position Mode (Refer to address 006&007.) 5: 1/4 Partial Scan Manual Start Position Mode (Refer to address 006&007.) 6: 1/6 Partial Scan Manual Start Position Mode (Refer to address 006&007.)
Partial Scan Manual Start Position	006 & 007	4~404: 1 ~ 401 lines ※The data of address 005 shall be 004 ~ 006. Address 006 MSB and Address 007 LSB make 6bit in total. Effective Area Start Position = (006&007) - 3 1/2 Scan Partial Mode Effective Data : 4 ~ 244 1/4 Scan Partial Mode Effective Data : 4 ~ 364 1/6 Scan Partial Mode Effective Data : 4 ~ 404
Manual Gain Control	008	0~32: 0 ~ 12dB ※Address 001 data shall be 003.

Function	Address	Data
Manual Shutter Control	009&010	4~525: 1/60(OFF) ~ 1/30,000s Normal Shutter Mode (When address 004 data is 000) 1/2 Scan Partial Mode Effective Data : 270 ~ 525 1/4 Scan Partial Mode Effective Data : 414 ~ 525 1/6 Scan Partial Mode Effective Data : 462 ~ 525 ※Address 002 data shall be 016. Address 009 MSB and Address 010 LSB make 16bit in total.
Trigger Polarity	011	0: Positive Input 1: Negative Input
Flip Mode	013	0: Normal output mode 1: Vertically inverted output mode 2: Horizontally inverted output mode 3: Vertically and Horizontally inverted output mode
Data Save	015	Input 083 to save address 000 ~ 014 to EEP-ROM.

6. External Connector Pin Assignment

14 pins PoCL-Lite Camera Link Connector 12214-1100-00PL (3M)

Pin No.	In/Out Signal
1	Vcc
2	SerTC+
3	X0-
4	X2-
5	Xclk-
6	CC1-(Trigger IN -)
7	GND
8	GND
9	SerTC-
10	X0+
11	X2+
12	Xclk+
13	CC1+(Trigger IN +)
14	Vcc

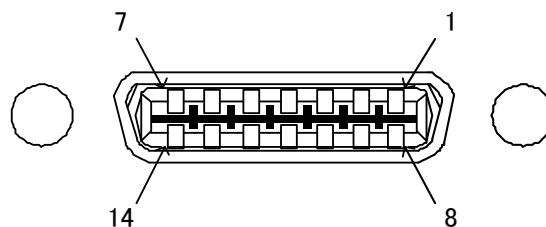

7. Timing Chart

7.1. Horizontal Synchronous Signal Timing

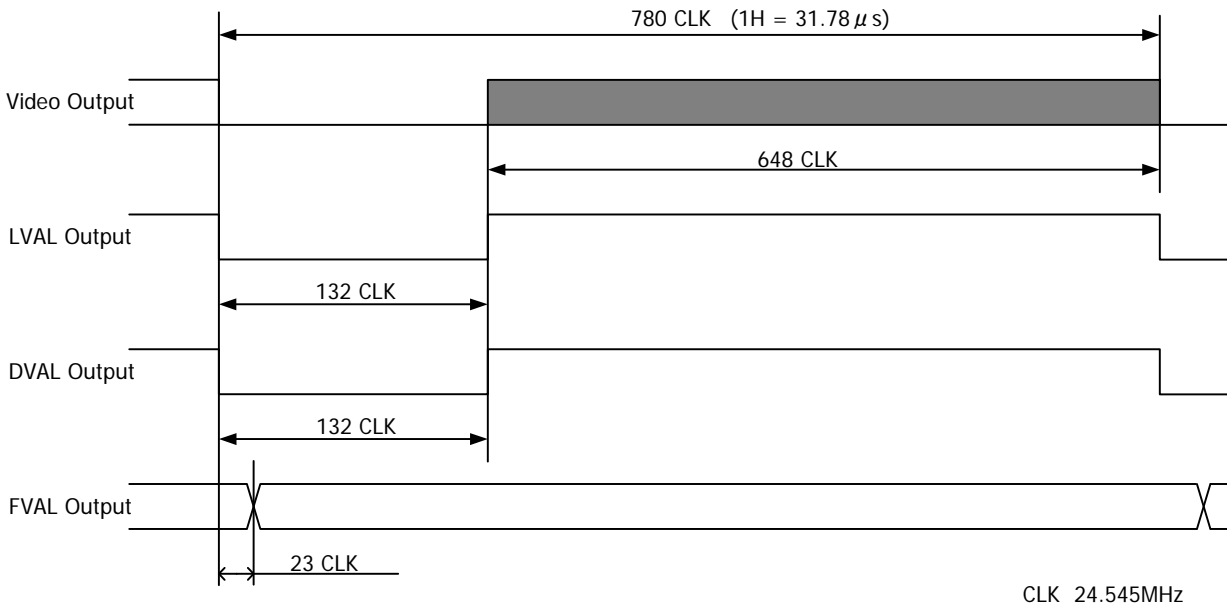

7.2. Vertical Synchronous Signal Timing

7.2.1. Full Frame Scan Mode

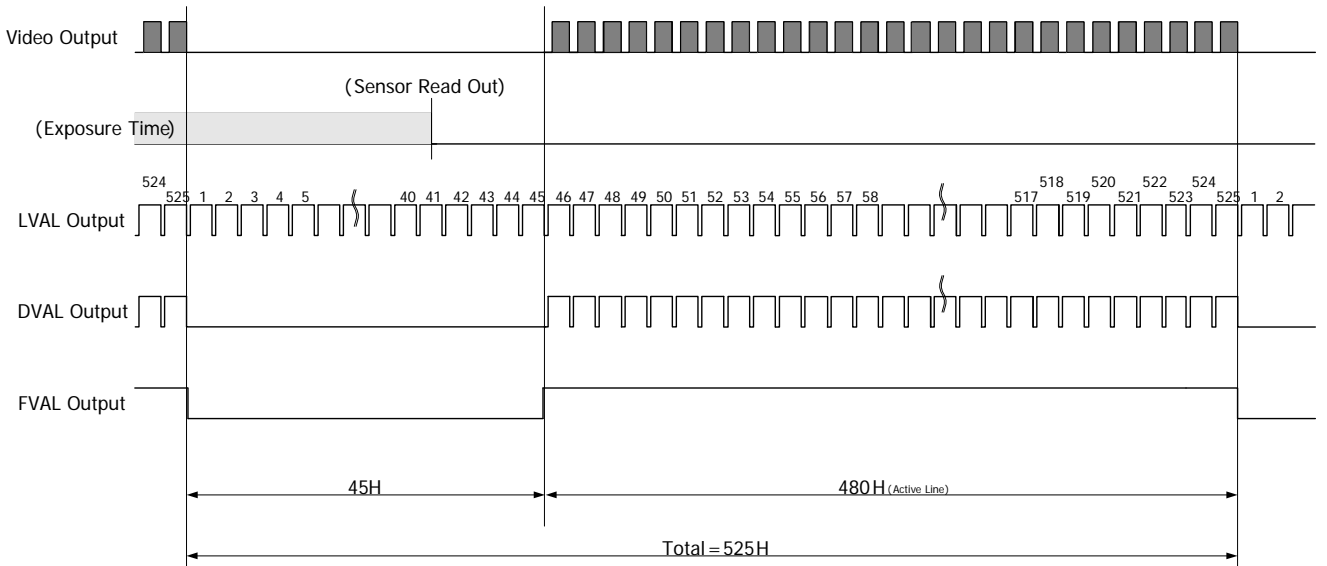

7.2.2. Partial Scan Mode

At each manual start position mode, capturing start position can be set per 1H.

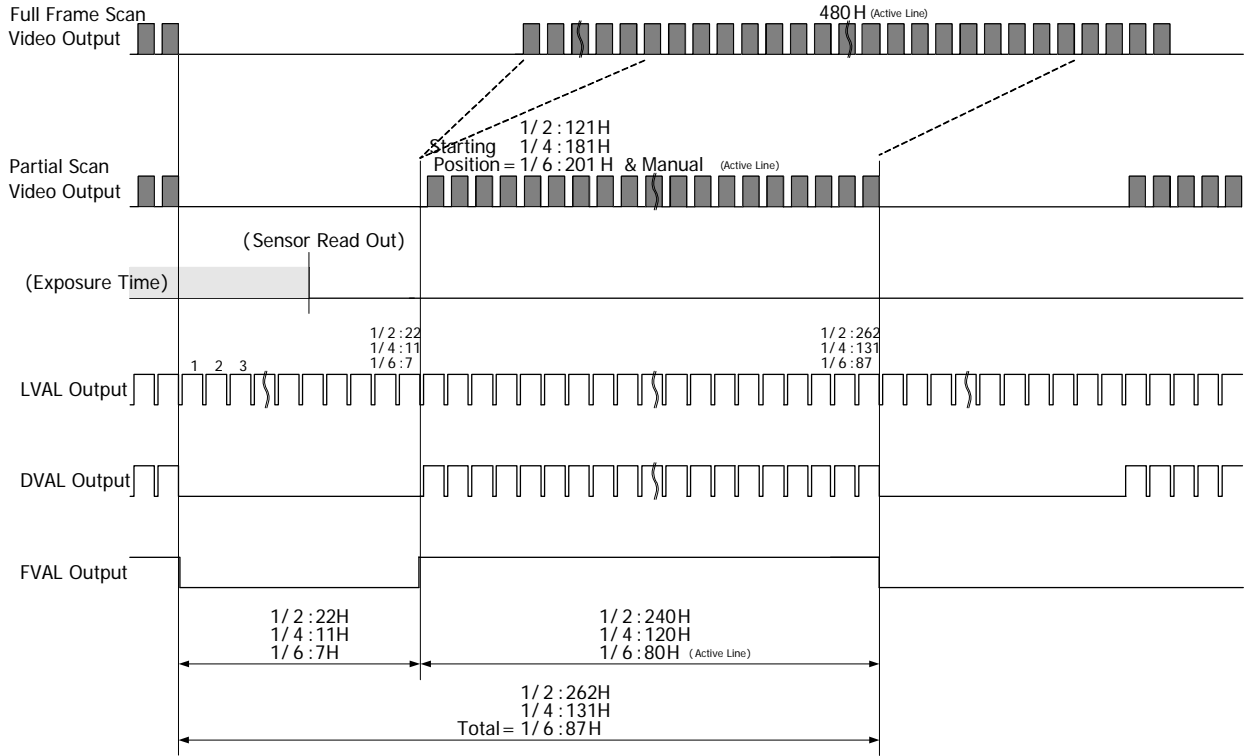

Manual Start Position (Address 006 & 007)

- 1/2 : 4 (1 H) ~ 244 (241 H)
- 1/4 : 4 (1 H) ~ 364 (361 H)
- 1/6 : 4 (1 H) ~ 404 (401 H)

7.3. Fixed Trigger Shutter Mode

- Trigger operation is CLK sync, V-Sync Reset.
Delay time, from detecting the trigger edge to starting exposure, is $10.6 \mu s$.
- The trigger input cannot be accepted when the camera is outputting video signals.
The new trigger input shall be input after completion of video signals for the prior trigger.
- Trigger pulse interval shall be over
Exposure time (set shutter speed nH) + effective video signals output time (H) + 45 (H)

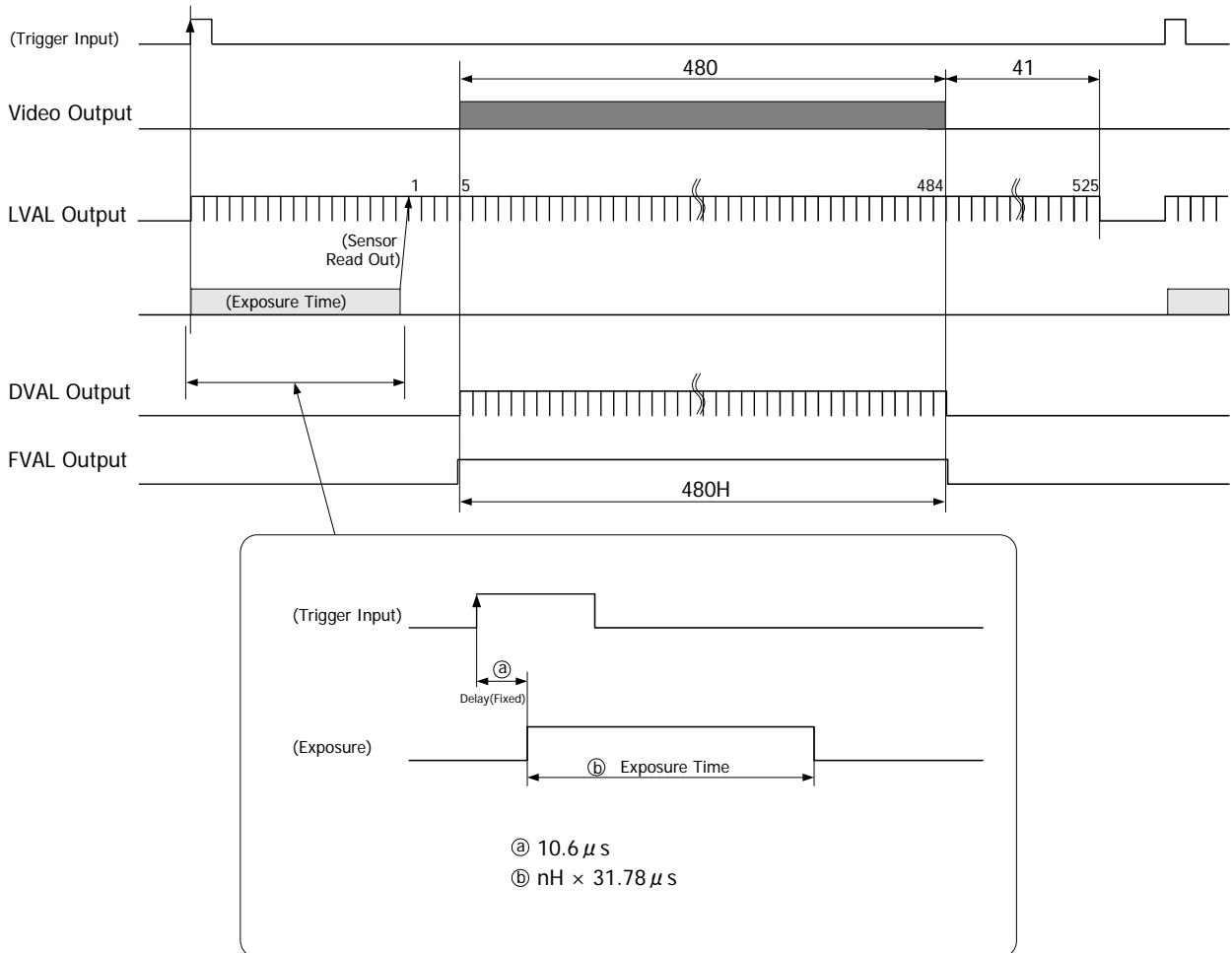

7.4. Pulse Width Trigger Shutter Mode

- Trigger operation is CLK sync, V-Sync Reset.
 Delay time, from detecting the trigger edge to starting exposure, is $5.34 \mu s$.
 Delay time, from detecting the trigger edge to completing exposure, is $8.35 \mu s$.
- The trigger input cannot be accepted when the camera is outputting video signals.
 The new trigger input shall be input after completion of video signals for the prior trigger.
- Trigger pulse width shall be within $22 \mu s \sim 500 \mu s$.
- Trigger pulse interval shall be over
 Exposure time (pulse width time + $3.01 \mu s$) + $2H$ + effective video signals output time (H) + $45(H)$

※ Please ask for trigger pulse width over than those above.

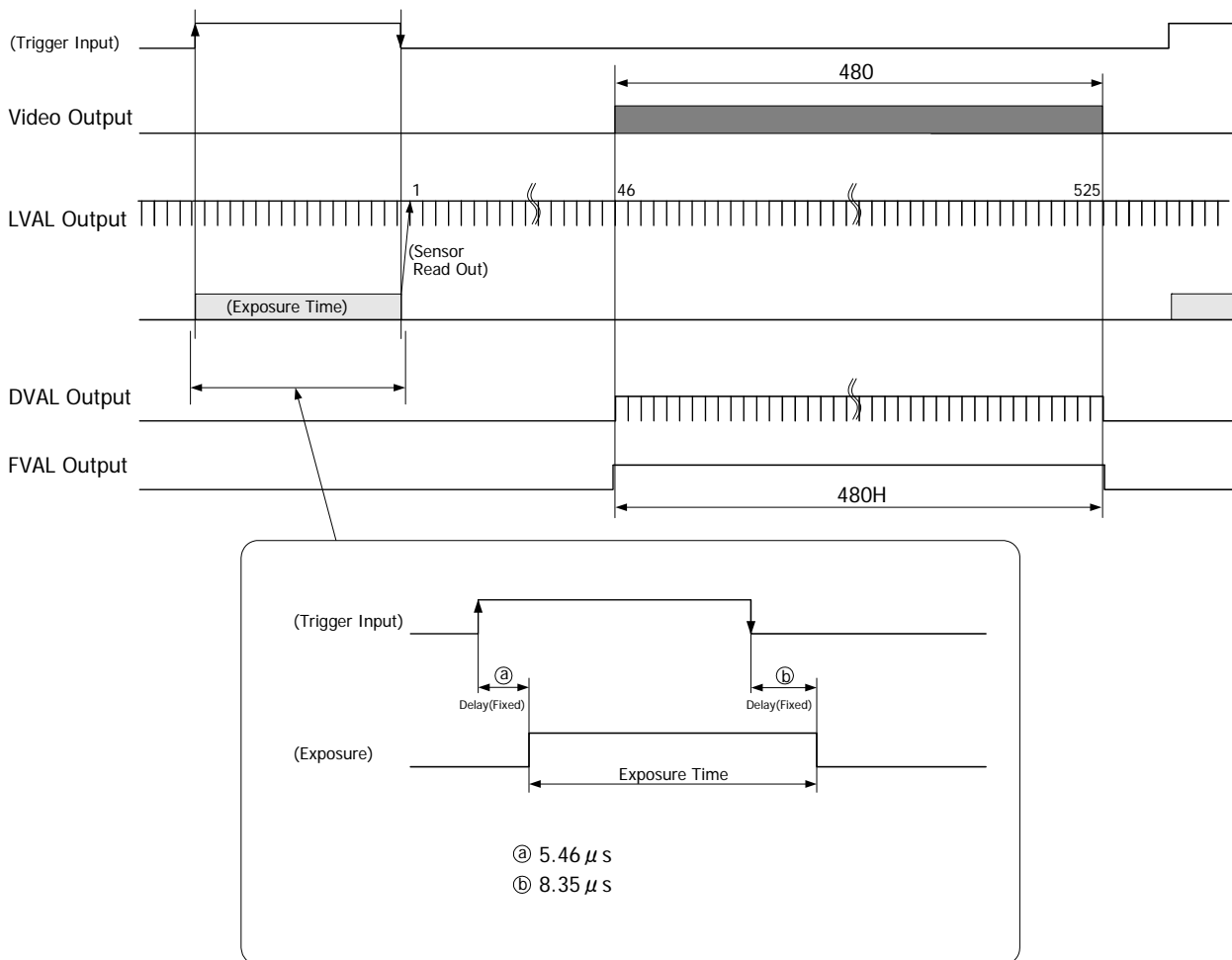

8. Remote Interface Function

Through RS-232C interface, the camera can be controlled via serial port of camera link connector.

(1) The settings for RS-232C are as follows.

Baud rate: 9600 bps
 Data: 8 bits
 Stop bit: 1 bit
 Parity: None
 XON/XOFF: not controlled

(2) Control code

- The total control code is 14 bits, which conforms to ASCII code.
- The control code consists of camera No. process code, remote controller address, remote controller data, and CR. Execute Read/Write through PC, and the camera will reply the data.

1	2	3	4	5	6	7th Byte	8	9	10	11	12	13	14
Camera No.						Process code	Remote controller address			Remote controller data			CR
00000: Fixed.						"R" Read mode	Please refer to the address table of 5.			000~255			0 Dh
						"W" Write mode							
						"C" Camera to reply	Function setting.						

Camera No. shall consist of 6 bytes of characters/numeric strings, "000000", fixed

Process code

Input any one of R, W, or C to the process code.

R (read mode) is to read the data of remote controller address.

Please be noted to set any dummy data (000~255) to 11th ~13th, since a command shall consists of 14 bytes.

W (write mode) is to write the data to the remote controller address.

Please be noted that the data cannot be saved into EEPROM of the camera.

(Reboot the camera, and the data is reset to the initial setting.)

To save the data into EEPROM, please refer to Clause 5.Function Setting.

Note: Once the data was saved into EEPROM, it may not be reset to the initial settings.

C is the code to send the data back from the camera.

Note: Do not set code C when sending the data from PC side.

Remote controller address

Note: Do not save the data into the address other than specified, since it may cause the damages or malfunction of the camera.

Remote controller data

Set the decimal number (000~255) for the remote controller data. Please be noted to set any dummy data at read mode.

CR

Be sure to input "CR" to confirm the end of the command.

※ 10ms should be waited to send the next command after receiving the response from the camera when changing the mode in succession.

9. Initial Settings

Function	Address	Data
Gain	001	0:0dB
E-Shutter	002	0:1/60s (OFF)
Trigger Mode	004	0: Normal Shutter Mode (Trigger OFF)
Scan Mode	005	0: Full Frame Scan Mode
Partial Scan Manual Start Position	006 & 007	4: 1 line
Manual Gain Control	008	0:0dB
Manual Shutter Control	009 & 010	4:1/60s (OFF)
Trigger Polarity	011	0: Positive Input
Flip	013	0:Normal Output Mode

10. CCD Optical Axis Accuracy

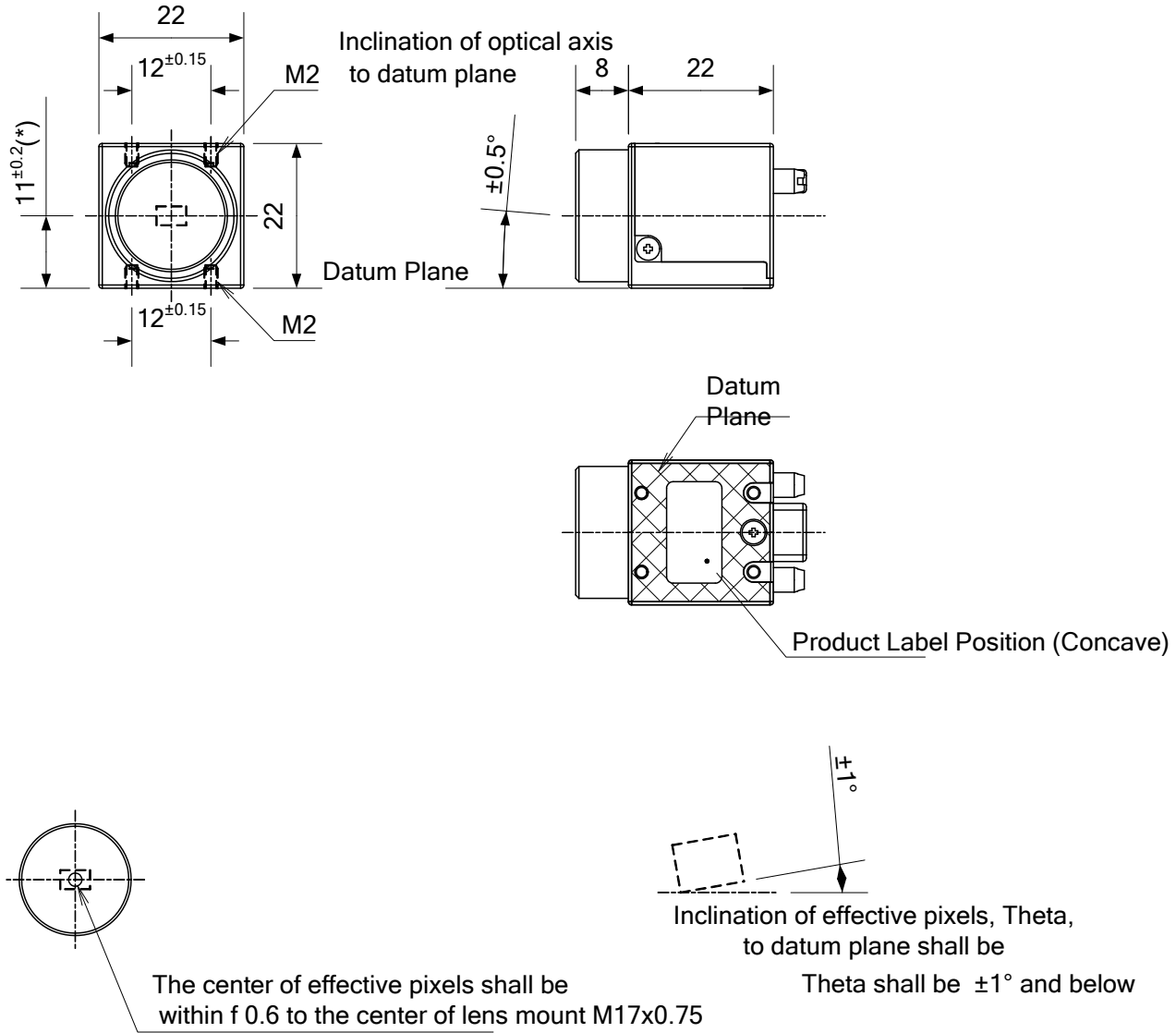

(*) Dimensions from datum plane to the center of the lens mount

910-011-00-00
(Unit: mm)

11. Dimensions

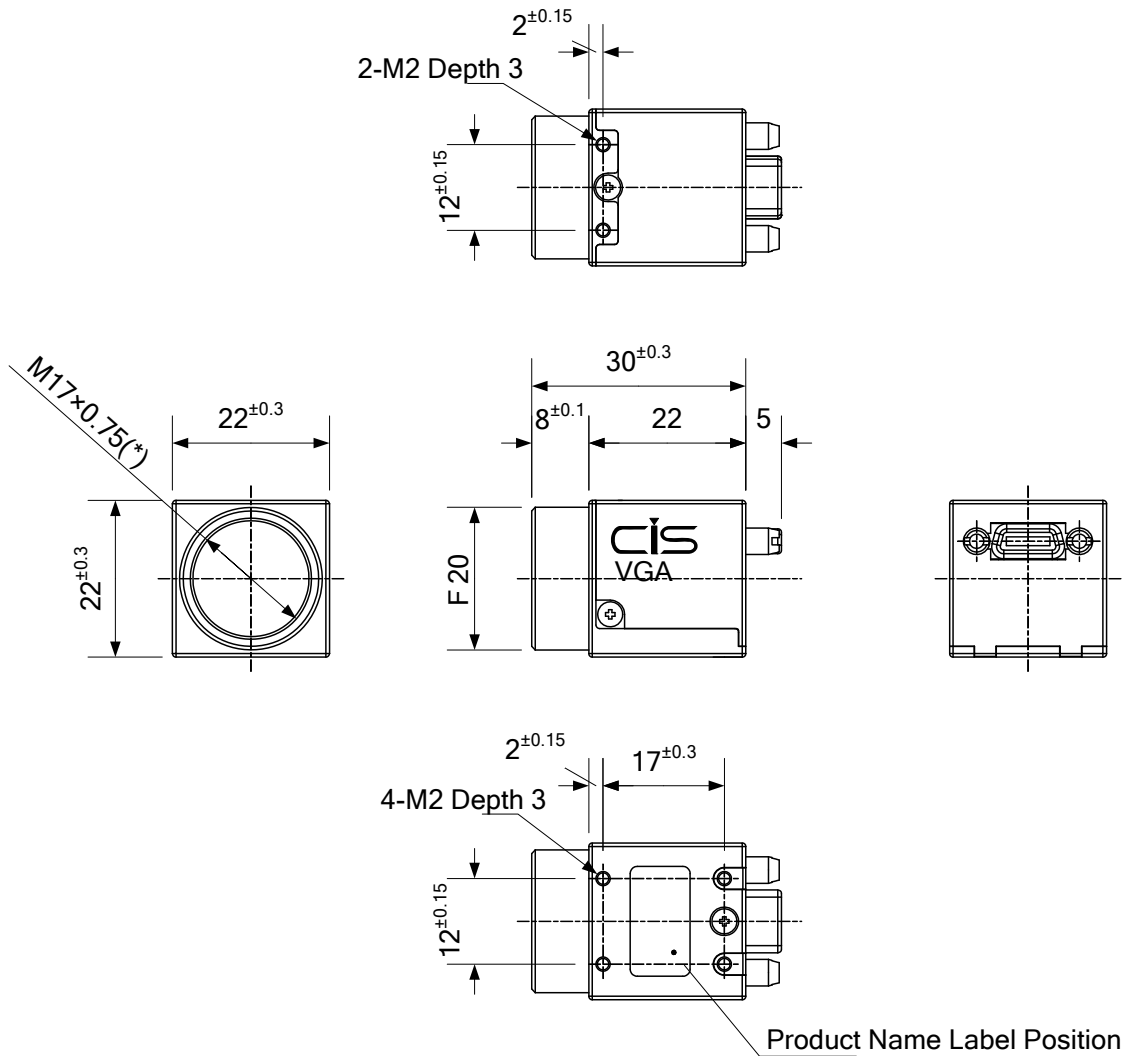

*) Screw length from the lens mount surface shall be under 6mm.
 And protruding portion shall be less than 6mm.

999-517-00-01
 (Unit: mm)

12. Cases for Indemnity (Limited Warranty)

We shall be exempted from taking responsibility and held harmless for damage or losses incurred by the user in the following cases.

- ✧ In case damage or losses are caused by fire, earthquake, or other acts of God, acts by third party, deliberate or accidental misuse by the user, or use under extreme operating conditions.
- ✧ In case indirect, additional, consequential damages (loss of business interests, suspension of business activities) are incurred as result of malfunction or non-function of the equipment, we shall be exempted from responsibility for such damages.
- ✧ In case damage or losses are caused by failure to observe the information contained in the instructions in this product specification & operation manual.
- ✧ In case damage or losses are caused by use contrary to the instructions in this product specification & operation manual.
- ✧ In case damage or losses are caused by malfunction or other problems resulting from use of equipment or software that is not specified.
- ✧ In case damage or losses are caused by repair or modification conducted by the customer or any unauthorized third party (such as an unauthorized service representative).
- ✧ Expenses we bear on this product shall be limited to the individual price of the product.

13. Sensor Pixel Defect

CIS compensates the noticeable Sensor pixel defects found at the shipping inspection prior to our shipment. On very rare occasions, however, Sensor pixel defects might be noted with time of usage of the products. Cause of the Sensor pixel defects is the characteristic phenomenon of CMOS itself and CIS is exempted from taking any responsibilities for them.

Should you have any questions on Sensor pixel defects compensation, please contact us.

14. Product Support

When defects or malfunction of our products occur, and if you would like us to investigate on the cause and repair, please contact your distributors you purchased from to consult and coordinate.