



English

**VISION:mini™**  
SXGA B/W Camera  
49MHz Pixel Clock Camera Link

**VCC-G22S21ACL**

**Product Specification**  
**& Operational Manual**

**CIS Corporation**

## Table of Contents

1. Scope of Application.....	3
2. Handling Precautions .....	3
3. Product Outline.....	5
4. Specification.....	6
4.1. General Specification .....	6
4.2. Camera Output Signal Specification.....	8
4.3. CCD Spectral Response (Representative value).....	9
5. Function Settings.....	10
6. External Connector Pin Assignment .....	12
6.1. 6 pins Circular Connector HR10-7R-6PA (HIROSE).....	12
6.2. 26pins camera Link connector 12226-1100-00 PL (SUMITOMO 3M) .....	12
7. Timing Chart.....	13
7.1. Horizontal Synchronous Signal Timing.....	13
7.2. Vertical Synchronous Signal Timing.....	13
7.2.1. Normal Shutter Mode (Trigger Shutter Mode OFF) .....	13
7.2.2. Trigger Shutter Mode.....	14
8. Remote Interface Function .....	15
9. Initial Settings .....	16
10. CCD Optical Axis Accuracy .....	17
11. Dimensions.....	18
12. Cases for Indemnity (Limited Warranty).....	19
13. CCD Pixel Defect.....	20
14. Product Support.....	20

## 1. Scope of Application

This is to describe VCC-G22S21ACL Power Over Camera Link B/W CCD Camera. All specifications contained herein are subject to change without prior notice. Reproduction in whole or in part is prohibited.

## 2. Handling Precautions

The camera must not be used for any nuclear equipments or aerospace equipments with which mechanical failure or malfunction could result in serious bodily injury or loss of human life. Our warranty does not apply to damages or defects caused by irregular and/or abnormal use of the product.

Please observe all warnings and cautions stated below.

Our warranty does not apply to damages or malfunctions caused by neglecting these precautions.

- Do not use or store the camera in the following extreme conditions:
  - Extremely dusty or humid places.
  - Extremely hot or cold places (operating temperature  $-5^{\circ}\text{C}$  to  $+45^{\circ}\text{C}$ )
  - Close to generators of powerful electromagnetic radiation such as radio or TV transmitters.
  - Places subject to fluorescent light reflections.
  - Places subject to unstable (flickering, etc.) lighting conditions.
  - Places subject to strong vibration.
- Remove dust or dirt on the surface of the lens with a blower.
- Do not apply excessive force or static electricity that could damage the camera.
- Do not shoot direct images that are extremely bright (e.g., light source, sun, etc.), and when camera is not in use, put the lens cap on.
- Follow the instructions in Chapter 6, "External connector pin assignment" for connecting the camera. Improper connection may cause damages not only to the camera but also to the connected devices.
- Confirm the mutual ground potential carefully and then connect the camera to monitors or computers. AC leaks from the connected devices may cause damages or destroy the camera.
- Do not apply excessive voltage. (Use only the specified voltage.) Unstable or improper power supply voltage may cause damages or malfunction of the camera.

- The voltage ripple of camera power DC  $+12V \pm 10\%$  shall be within  $\pm 50mV$ . Improper power supply voltage may cause noises on the video signals.
- The rising time of camera power supply voltage shall be less than  $+10V$ , Max 60ms. Please avoid noises like chattering when rising.

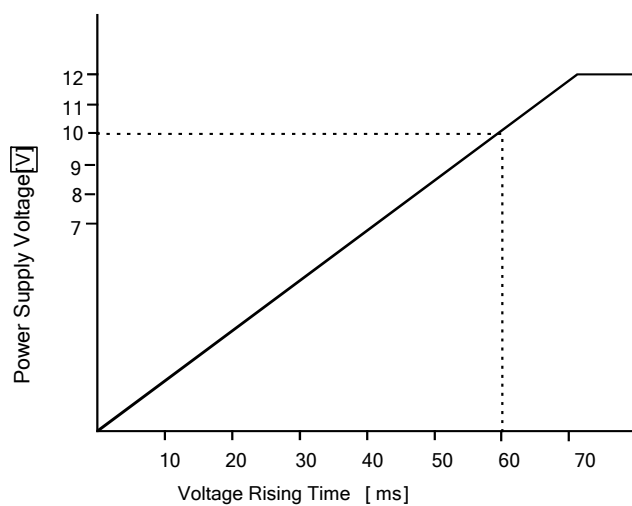

In case of abnormal operation, contact the distributor from whom you purchased the product.

### 3. Product Outline

VCC-G22S21ACL is a high-resolution industrial B/W digital video camera module utilizing a 1/2 type PS IT CCD. 1.45M pixels CCD image sensor with on-chip micro-lenses realizes high sensitivity and high resolution. At Full Frame Scan Mode, entire pixels can be read out within approx. 1/25s. Interface of G22S21ACL complies with camera link standard.

#### Key Features

- Camera settings can be changed via serial communications.
- Selectable 8 bit or 10 bit.
- 1/25~1/90,000s shutter speeds can be set per 1H.
- Full frame scan mode and three different partial scan modes are available.
- Approx. 25 fps at full frame scan mode.
- Only 29mm cubic in size (excluding projection), light weight 50g, and speed makes it a best match for use in embedded systems.

## 4. Specification

## 4.1. General Specification

Item	Specification	
Pickup device	Device Type	1/2 type Interline Transfer B/W CCD, Sony ICX267AL
	Effective Pixel Number	1392(H) x 1040 (V)
	Recommended Pixels	1360(H) x 1024(V)
	Unit Cell Size	4.65 $\mu$ m (H) x 4.65 $\mu$ m (V)
	Chip Size	7.60mm (H) x 6.20mm (V)
Video output frequency	Pixel Clock	49.0908 MHz
	Horizontal Frequency	27.425KHz Pixel Clock: 1790 CLK
	Vertical Frequency	Full Frame Scan Mode: 1068H, approx 25 Hz
		Partial Scan Mode 1: 835H, approx 33 Hz
Partial Scan Mode 2: 667H, approx 41 Hz		
	Partial Scan Mode 3: 547H, approx 50 Hz	
Sync. system	Internal Sync. System	
Video output standard	Camera Link	
Resolution	1024 TV lines	
Resolving power	8bit / 10bit	
Sensitivity	F5.6 400 lx (Shutter 1/25s, Gain 0dB)	
Minimum illumination	F1.4 2.0 lx (Shutter 1/25s, Gain +12dB)	
Dust or stains in optical system	No dust or stain shall be detected on the testing screen with setting the camera aperture at F16.	
Power requirements	DC +12V $\pm$ 10% (Max voltage not to exceed 15V)	
Power consumption	2.7 W (DC +12V IN)	
Dimension	Refer to overall dimension drawing (Clause 11) 29mm x 29mm x 29mm (excluding projection)	
Mass	Approx. 50 g	
Lens mount	C mount (Refer to overall dimension drawing )	
Optical axis accuracy	Refer to drawing for CCD Optical Axis Accuracy (Clause 10)	
Gain variable range	-1 ~ +12dB	
Shutter speed variable range	OFF (1/25), 1/50, 1/100, 1/250, 1/500, 1/1000, 1/2000, 1/4000, 1/10000, 1/20000, 1/90000s	
Trigger shutter mode	<ul style="list-style-type: none"> <li>• Fixed Trigger Shutter Mode</li> <li>• Pulse Width Trigger Shutter Mode</li> </ul> *Trigger pulse width shall be over 1H and less than 1/2s.	

Item	Specification	
Safety/Quality standards	UL: Conform to UL Standard including materials and others. RoHS: Conform to RoHS CE: Conform to EN55022:2006 (Class A): Emission Conform to EN61000-6-2:2005: Immunity FCC: To be applied to FCC Class A digital Device This device complies with Part 15 of the FCC Rules. Operation is subject to the following two conditions: (1) this device may not cause harmful interference, and (2) this device must accept any interference received, including interference that may cause undesired operation.	
Durability	Vibration	Acceleration 98 m/s <sup>2</sup> (10.0G)
		Frequency 20~200 Hz
		Direction XYZ 3 directions
		Testing time 120 min for each direction
	Shock	No malfunction shall be occurred with 490m/s <sup>2</sup> (50G) for ±X, ±Y, and ±Z, 6 directions. (without package)
Operation environment	Temperature	Operation guaranteed: -5°C~+45°C Performance guaranteed: 0°C~+40°C
	Humidity	RH 20~80% with no condensation
Storage environment	Temperature	-25°C ~ +60°C
	Humidity	RH 20~80% with no condensation

4.2. Camera Output Signal Specification

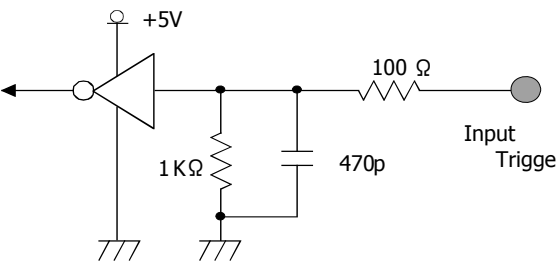
Item		Specification	
Video output data	Video out	1392 (H) x 1040 (V)	At Full Frame Scan Mode
	Recommended	1360 (H) x 1024 (V)	
Sync. Signal I/O	LVAL output	LVDS	Camera Link connector
	FVAL output	LVDS	
	DVAL output	LVDS	
	HD/VD input	None	
Trigger input	Polarity	POSI/NEGA Selectable	
	Min. Trigger Pulse width	Over 1 HD	
	Camera Link input	LVDS: CC1 input	Camera Link connector
	TTL Input	Refer to the following drawing	HR10-7R-6PA
		$V_{IH} \text{ Min}2.0V$ $V_{IL} \text{ Max}0.8V$	
Video output signal	White Clip Level	Digital 8bit	: FFh
		Digital 10bit	: 3FFh
	Setup Level	Digital 8bit	: 08 ± 03h
		Digital 10bit	: 020 ± 00Ch

5 seconds shall be waited after turning on power to get proper camera operation.

### 4.3. CCD Spectral Response (Representative value)

※ Lens characteristics and illuminant characteristics are not considered.

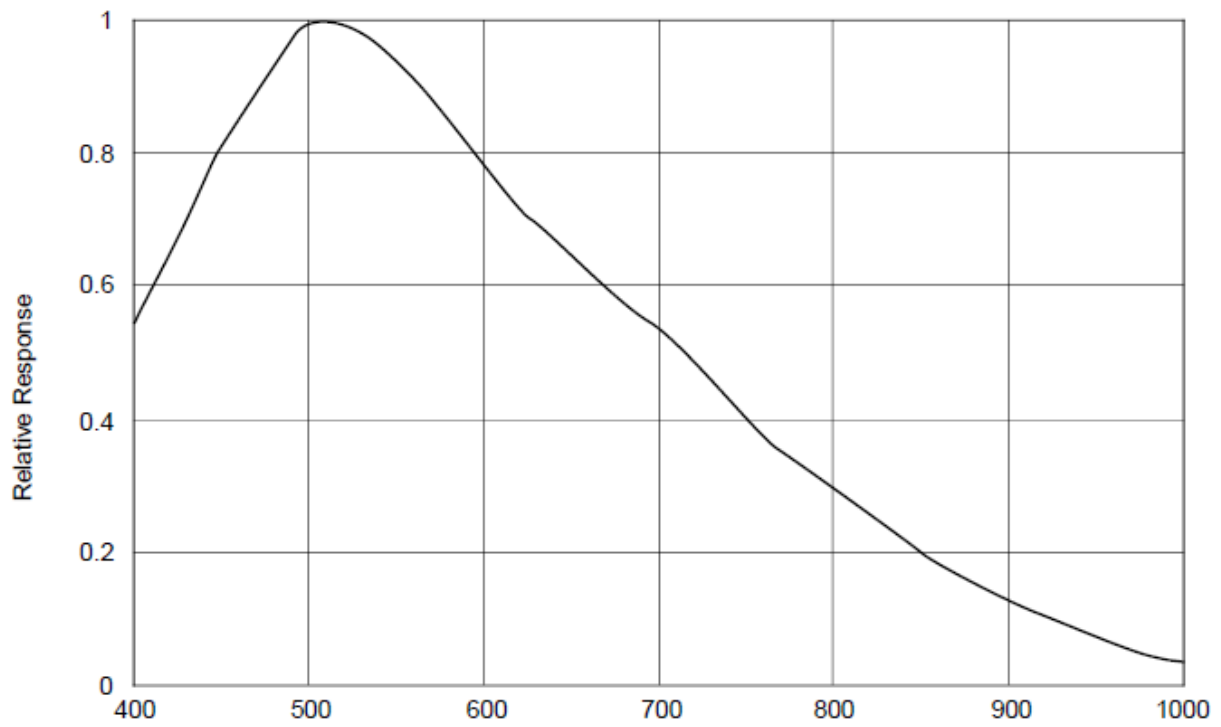

## 5. Function Settings

Camera functions can be set with serial data communications.

Gain	001	0:	-1 dB
		1:	0 dB
		2:	+6 dB
		3:	+12 dB
		4:	Manual Gain (Refer to Address 008)
E-Shutter	002	0:	1/25s (Off)
		1:	1/50s
		2:	1/100s
		3:	1/250s
		4:	1/500s
		5:	1/1000s
		6:	1/2000s
		7:	1/4000s
		8:	1/10000s
		9:	1/20000s
		10:	1/90000s
		11~ 15:	1/25s (Off)
		16:	Manual Shutter (Refer to Address 009&010)
No Function	003	0:	Fixed. Do not change.
Trigger Mode	004	0:	Normal Shutter Mode (Trigger Shutter Mode Off)
		1:	Fixed Trigger Shutter Mode (Shutter speed can be set with address 002.)
		2:	Pulse Width Trigger Shutter Mode (Shutter speed can be set with trigger pulse width.)
Scan Mode	005	0:	Full Frame Scan Mode
		1:	Partial Scan Mode 1
		2:	Partial Scan Mode 2
		3:	Partial Scan Mode 3
No Function	006	0:	Fixed. Do not change.
No Function	007	0:	Fixed. Do not change.
Manual Gain Control	008	0~ 255:	-1dB~+12dB ※Set the data of address 001 to 004.
Manual Shutter Control	009& 010	0~ 524:	1/25s~1/90000s
			※Set the data of address 002 to 016.
			Address 009 MSB and address 010 LSB makes 10bit in total. Shutter Speed = (1067.3-Data) x 36.46μs
			Max Data = 42Bh = 1067
Trigger Polarity	011	0:	Positive Input
		1:	Negative Input
Input Trigger Port Select	012	0:	26pin Camera Link connector (12226-1100-00 PL) LVDS
		1:	6pin circular connector (HR10-7R-6PA) TTL

Output Data Selection	013	0:	8 bit output data
		1:	10 bit output data
		2:	PoCL-Lite 8 bit output data
		3:	PoCL-Lite 10 bit output data
Trigger Reset Mode	014	0:	H-Synchronous Mode
		1:	CLK-Synchronous Mode
Data Save	015	Input 083 to save address 000~014 into EEPROM.	

Note: Please note the followings when using trigger shutter mode.

Re-triggering at H-Synchronous Mode shall be after 2H of CCD read out signal.

Re-triggering at CLK-Synchronous Mode shall be after completion of video output.

Trigger pulse width shall be within the range of over 1HD to less than 1/2 sec.

## 6. External Connector Pin Assignment

### 6.1. 6 pins Circular Connector HR10-7R-6PA (HIROSE)

Pin No.	
1	Power IN +12V
2	Trigger IN (TTL Level)
3	RS-232C RXD (option)
4	RS-232C TXD (option)
5	Do not connect
6	GND

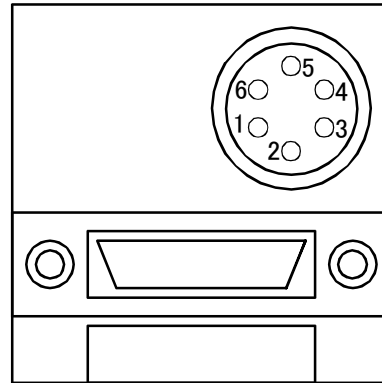

### 6.2. 26pins camera Link connector 12226-1100-00 PL (SUMITOMO 3M)

Pin No.		Pin No.	
1	GND	14	GND
2	X0-	15	X0+
3	X1-	16	X1+
4	X2-	17	X2+
5	Xclk-	18	Xclk+
6	X3-	19	X3+
7	SerTC+	20	SerTC-
8	SerTFG-	21	SerTFG+
9	CC1- (Trigger IN-)	22	CC1+ (Trigger IN+)
10	CC2+	23	CC2-
11	CC3-	24	CC3+
12	CC4+	25	CC4- (GND)
13	GND	26	GND

7. Timing Chart

7.1. Horizontal Synchronous Signal Timing

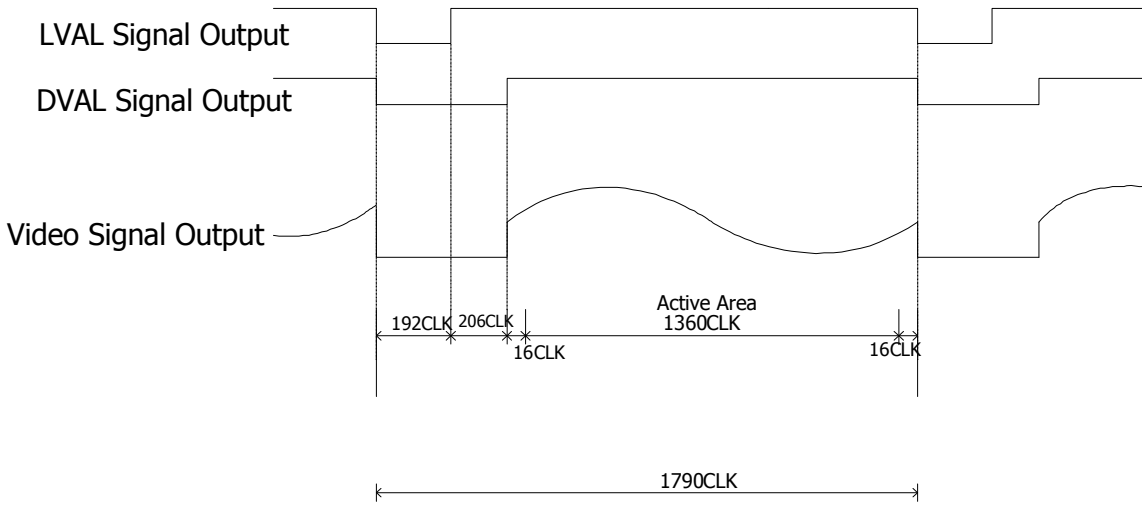

7.2. Vertical Synchronous Signal Timing

7.2.1. Normal Shutter Mode (Trigger Shutter Mode OFF)

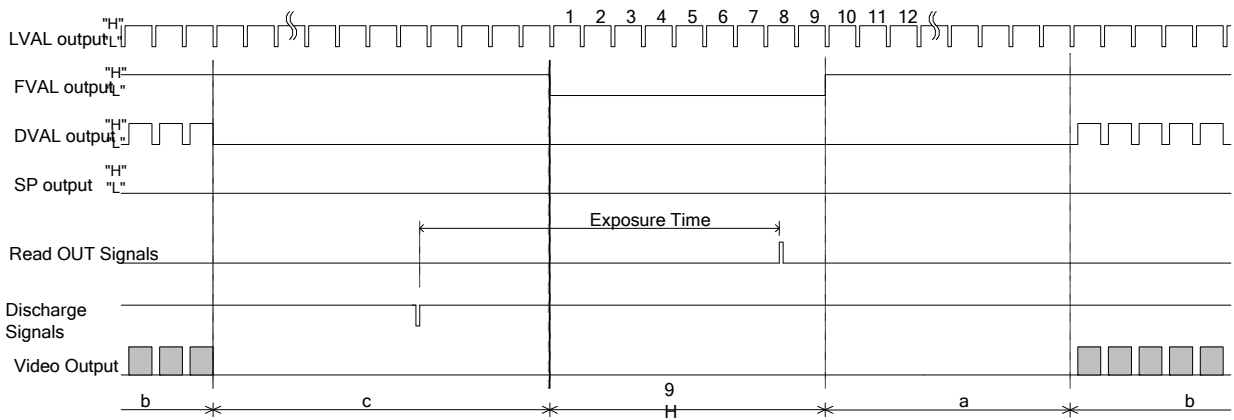

Scan Mode	a line number	b line number	c line number	Total line numbers
Full Frame Scan Mode	8 H	1040 H	11 H	1068 H
Partial Scan Mode 1	29 H	770 H	27 H	835 H
Partial Scan Mode 2	50 H	560 H	48 H	667 H
Partial Scan Mode 3	65 H	410 H	63 H	547 H

\* Recommended numbers of output lines at full frame scan mode is 1024H dividing at the center.

### 7.2.2. Trigger Shutter Mode

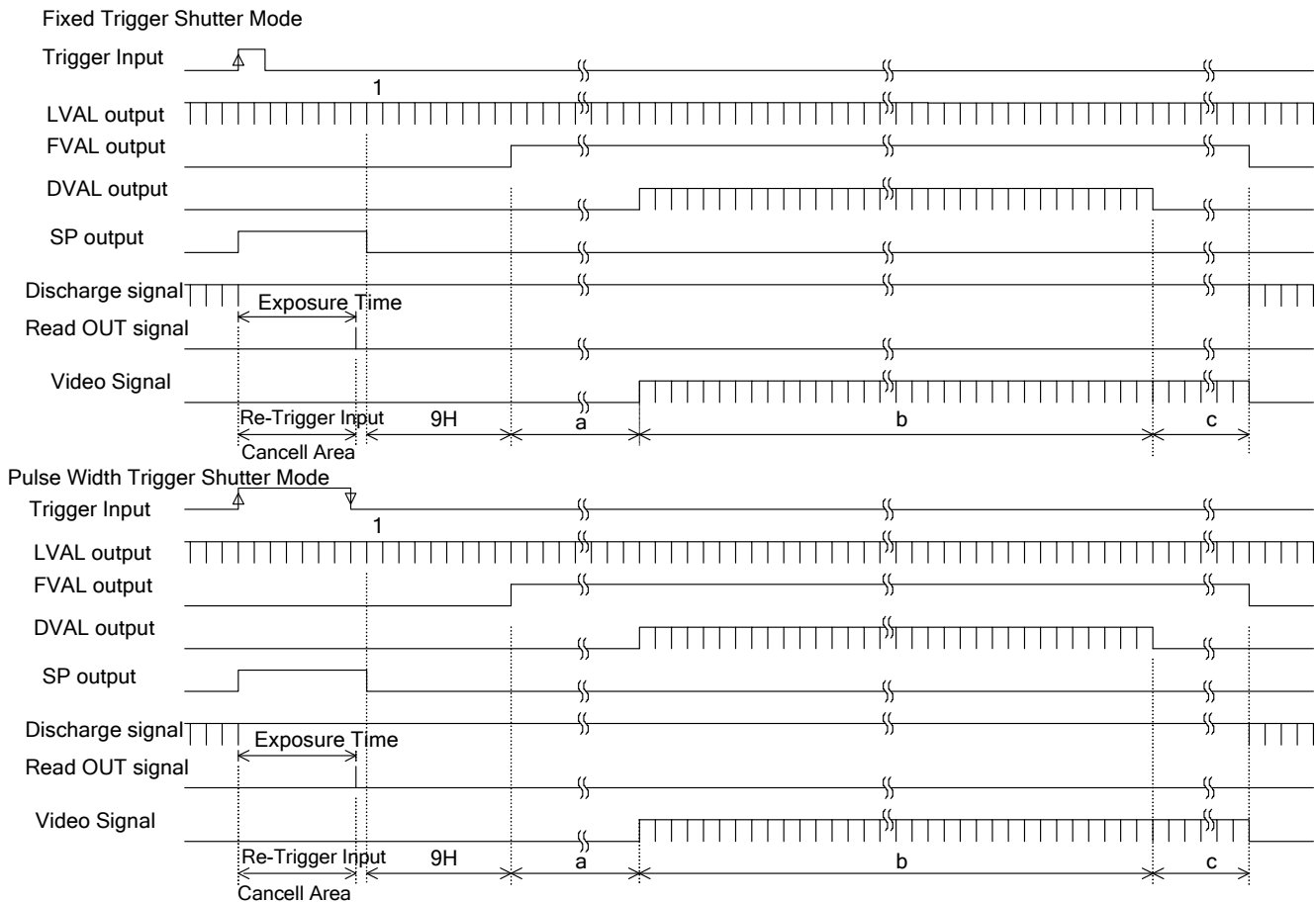

Scan Mode	a line number	b line number	c line number	Total line numbers
Full Frame Scan Mode	8 H	1040 H	11 H	1068 H
Partial Scan Mode 1	29 H	770 H	27 H	835 H
Partial Scan Mode 2	50 H	560 H	48 H	667 H
Partial Scan Mode 3	65 H	410 H	63 H	547 H

### CLK- Synchronous Mode Details at Pulse Width Trigger Shutter Mode

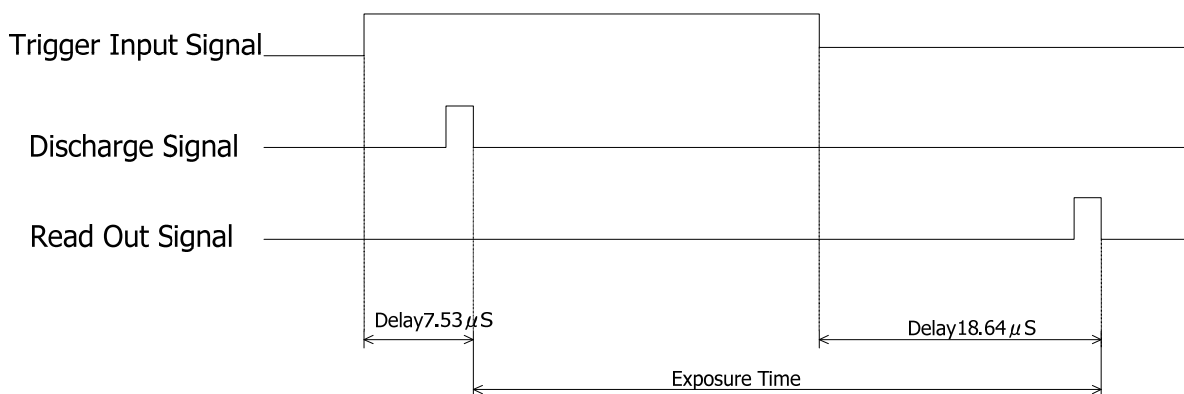

## 8. Remote Interface Function

Through RS-232C interface, the camera can be controlled by external PC.

(1) The settings for RS-232C are as follows.

Baud rate: 9600 bps  
 Data: 8 bits  
 Stop bit: 1 bit  
 Parity: None  
 XON/XOFF: not controlled

(2) Control code

- The total control code is 14 bits, which conforms to ASCII code.
- The control code consists of camera No. process code, remote controller address, remote controller data, and CR. Execute Read/Write through PC, and the camera will reply the data.

1	2	3	4	5	6	7th Byte	8	9	10	11	12	13	14
Camera No.						Process code	Remote controller address			Remote controller data			CR
00000: Common to the all cameras.						"R" Read mode	Please refer to the address table of 5. Function Settings.			000~255			0 Dh
000001~ZZZZZ: Camera No. of individual camera.						"W" Write mode							
						"C" Camera mode							

Camera No. shall consist of 6 bytes of characters/numeric strings.

Send the individual camera number code or common number code, "000000".

The reply data from the camera shall contain the registered number for that camera.

Process code

Input any one of R, W, or C to the process code.

R (read mode) is to read the data of remote controller address.

Please be noted to set any dummy data (000~255) to 11<sup>th</sup> ~13<sup>th</sup>, since a command shall consists of 14 bytes.

W (write mode) is to write the data to the remote controller address.

Please be noted that the data cannot be saved into EEPROM of the camera.

(Reboot the camera, and the data is reset to the initial setting.)

To save the data into EEPROM, please refer to Clause 5.4. Function Setting.

**Note: Once the data was saved into EEPROM, it may not be reset to the initial settings.**

C is the code to send the data back from the camera.

**Note: Do not set code C when sending the data from PC side.**

Remote controller address

**Note: Do not save the data into the address other than specified, since it may cause the damages or malfunction of the camera.**

Remote controller data

Set the decimal number (000~255) for the remote controller data. Please be noted to set any dummy data at read control mode.

CR

Be sure to input "CR" to confirm the end of the command.

※ 10ms should be waited to send the next command after receiving the response from the camera when changing the mode in succession.

## 9. Initial Settings

Gain	001	1:0dB
E-Shutter	002	0:1/25s (Off)
Trigger Mode	004	0: Normal Shutter Mode (Trigger Shutter Mode Off)
Scan Mode	005	0: Full Frame Scan Mode
Manual Gain Control	008	Invalid
Manual Shutter Control	009&010	Invalid
Trigger Polarity	011	0: Positive Input
Input Trigger Port Select	012	0: 26 pins Camera Link connector (12226-1100-00 PL)
Output Data Select	013	0:8bit Output Data
Trigger Reset Mode	014	0: H-Synchronous Mode

10. CCD Optical Axis Accuracy

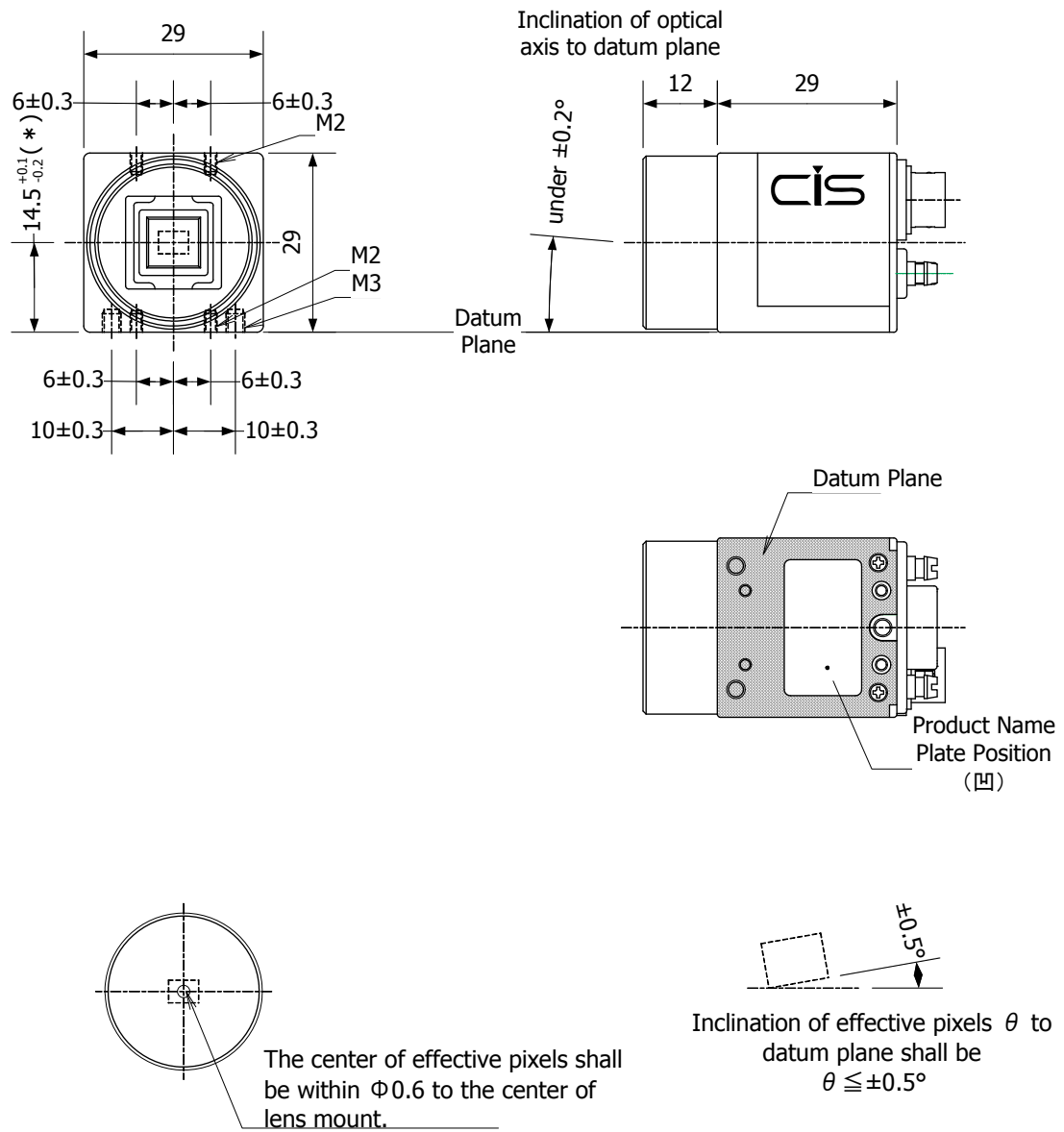

(\*) Dimension from datum plane to the center of lens mount.

11. Dimensions

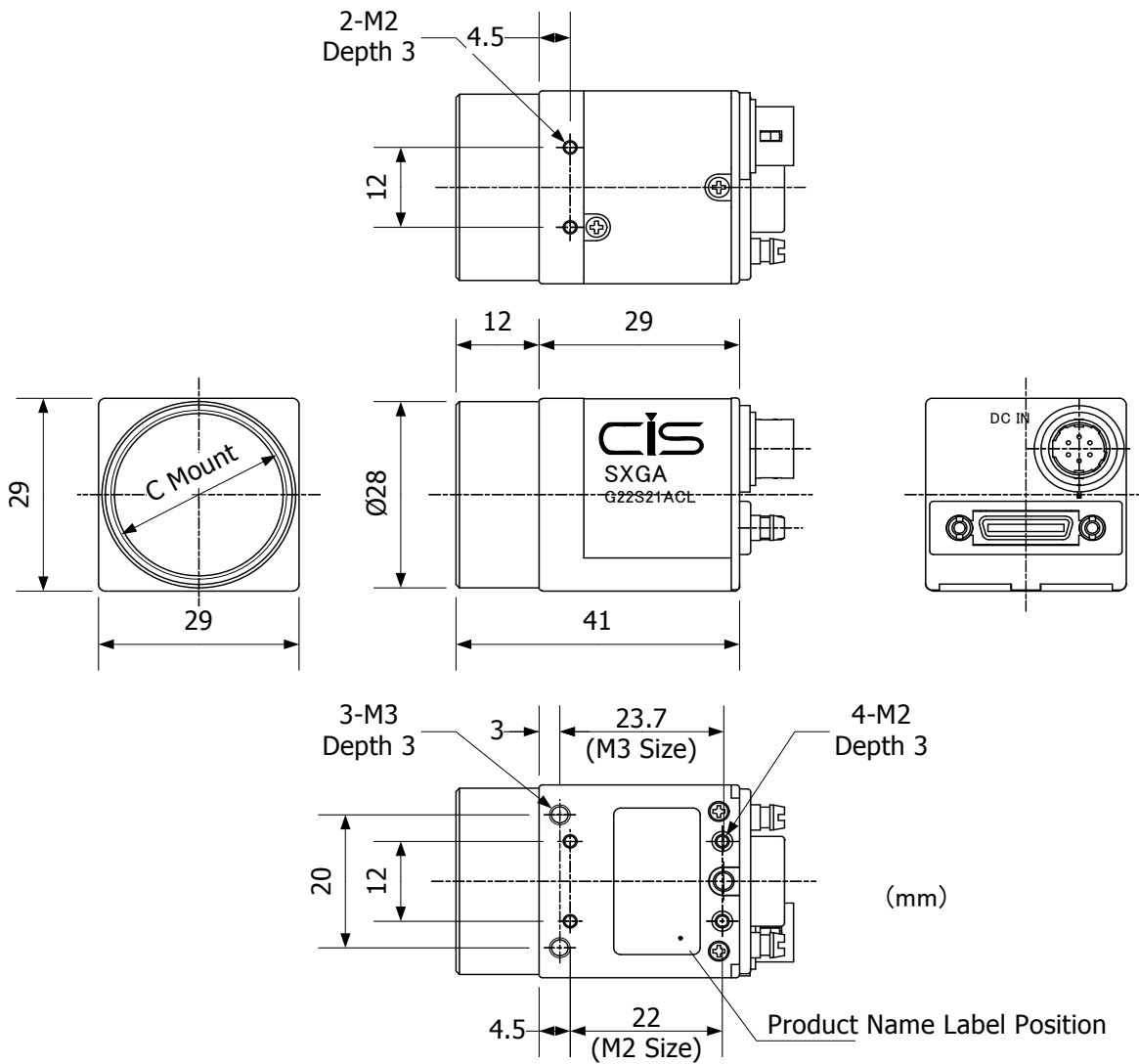

- ※ C Mount screws comply with ANSI/ASME B1.1, 1-32UN (2B)
- ※ Screw length from C mount lens surface shall be under 6mm. And, protruding portion shall be less than 10mm.

999-481-00-00

## 12. Cases for Indemnity (Limited Warranty)

We shall be exempted from taking responsibility and held harmless for damage or losses incurred by the user in the following cases.

- ✧ In case damage or losses are caused by fire, earthquake, or other acts of God, acts by third party, deliberate or accidental misuse by the user, or use under extreme operating conditions.
- ✧ In case indirect, additional, consequential damages (loss of business interests, suspension of business activities) are incurred as result of malfunction or non-function of the equipment, we shall be exempted from responsibility for such damages.
- ✧ In case damage or losses are caused by failure to observe the information contained in the instructions in this product specification & operation manual.
- ✧ In case damage or losses are caused by use contrary to the instructions in this product specification & operation manual.
- ✧ In case damage or losses are caused by malfunction or other problems resulting from use of equipment or software that is not specified.
- ✧ In case damage or losses are caused by repair or modification conducted by the customer or any unauthorized third party (such as an unauthorized service representative).
- ✧ Expenses we bear on this product shall be limited to the individual price of the product.

### 13. CCD Pixel Defect

CCD pixel defects might be noted with time of usage of the products. Cause of the CCD pixel defects is the characteristic phenomenon of CCD itself and CIS is exempted from taking any responsibilities for them.

### 14. Product Support

When defects or malfunction of our products occur, and if you would like us to investigate on the cause and repair, please contact your distributors you purchased from to consult and coordinate.

Control SW

Sample software for camera control (RS-232C) can be downloaded from our home page.

URL: <http://www.ciscorp.co.jp>

We shall be exempted from taking responsibility and held harmless for damage or malfunction of your hardware and software caused by using this control software. The purpose of this control software is for you to check operation and evaluate our products. Please be noted that CIS does not customize the program nor provide source code.