



English

VISION:analog™

**29mm Cubic VGA
B/W Analog Camera**

VCC-G20V30A

**Product Specification
& Operational Manual**

CIS Corporation

Table of Contents

1. Scope of Application.....	3
2. Handling Precautions	3
3. Product Outline.....	4
4. Specification.....	5
4.1. General Specification	5
4.2. Camera Input/Output Signal Specification.....	7
4.3. CCD Spectral Response (Representative value).....	8
5. Function Settings.....	9
6. External Connector Pin Assignment	13
6.1. 12 pins Circular Connector HR10-10R-12PA (HIROSE)	13
7. Timing Chart.....	14
7.1. Horizontal Sync Timing	14
7.2. Vertical Sync Timing	14
7.2.1. Full Frame Scan Mode.....	14
7.2.2. 2:1 Interlaced Scan Mode (At Normal Shutter Mode).....	15
7.2.3. Binning Mode (At Trigger Shutter Mode)	15
7.2.4. 1/2 Partial Scan Mode.....	16
7.2.5. 1/4 Partial Scan Mode.....	16
7.3. Restart-Reset Mode (Long Time Exposure) Timing	17
7.4. Trigger Shutter Mode Timing	17
7.4.1. Fixed Trigger Shutter Mode (Sync Reset).....	17
7.4.2. Pulse Width Trigger Shutter Mode 1 (Sync Rese).....	18
7.4.3. Pulse Width Trigger Shutter Mode 2 (Sync Non-Reset)	18
8. CCD Optical Axis Accuracy	19
9. Dimensions	20
10. Cases for Indemnity (Limited Warranty).....	21
11. CCD Pixel Defect.....	22
12. Product Support.....	22

1. Scope of Application

This is to describe VCC-G20V30A analog B/W CCD Camera. All specifications contained herein are subject to change without prior notice. Reproduction in whole or in part is prohibited.

2. Handling Precautions

The camera must not be used for any nuclear equipments or aerospace equipments with which mechanical failure or malfunction could result in serious bodily injury or loss of human life. Our warranty does not apply to damages or defects caused by irregular and/or abnormal use of the product.

Please observe all warnings and cautions stated below.

Our warranty does not apply to damages or malfunctions caused by neglecting these precautions.

- Do not use or store the camera in the following extreme conditions:
 - Extremely dusty or humid places.
 - Extremely hot or cold places (operating temperature -5°C to $+45^{\circ}\text{C}$)
 - Close to generators of powerful electromagnetic radiation such as radio or TV transmitters.
 - Places subject to fluorescent light reflections.
 - Places subject to unstable (flickering, etc.) lighting conditions.
 - Places subject to strong vibration.
- Do not apply excessive force or static electricity that could damage the camera.
- Do not shoot direct images that are extremely bright (e.g., light source, sun, etc.), and when camera is not in use, put the lens cap on.
- Follow the instructions in Chapter 6, "External connector pin assignment" for connecting the camera. Improper connection may cause damages not only to the camera but also to the connected devices.
- Confirm the mutual ground potential carefully and then connect the camera to monitors or computers. AC leaks from the connected devices may cause damages or destroy the camera.
- Do not apply excessive voltage. (Use only the specified voltage.) Unstable or improper power supply voltage may cause damages or malfunction of the camera.
- The voltage ripple of camera power DC $+12\text{V} \pm 10\%$ shall be within $\pm 50\text{mV}$. Improper power supply voltage may cause noises on the video signals.

In case of abnormal operation, contact the distributor from whom you purchased the product.

3. Product Outline

VCC-G20V30A is a high-resolution industrial B/W analog camera module utilizing a 1/3" inch PS IT CCD. 330K pixels CCD image sensor with on-chip micro-lenses realizes high sensitivity and high resolution.

Key Features

- HD/VD sync input or Trigger input are valid.
- OFF and 1/200s ~ 1/20,000s , 8 steps shutter speed can be set by rear switch.
10 μ s ~ 250ms shutter speed can be set by trigger pulse width.
- Frame rates, 60fps and 30fps, are selectable.
- 1/2 Partial scan mode, 1/4 Partial scan mode, and Binning mode are available.
- Restart Rest mode to enable long time exposure can be set.
- 2:1 Interlaced Mode (at normal shutter mode) is available.
- Scanning rates are switchable by the input level to 9pins circular connector at rear.
- Only 29mm cubic in size (excluding projection), light weight 45g, and speed makes it a best match for use in embedded systems.
- As an optional function, $\gamma = 0.45$, HD/VD 75 Ω impedance can be set as the factory initial setting.
Please ask us for the details.

4. Specification

4.1. General Specification

Item	Specification				
Pickup device	Device Type	1/3" Interline Transfer B/W CCD, Sony ICX424AL			
	Effective Pixel Number	659(H) x 494 (V)			
	Unit Cell Size	7.4 μ m (H) x 7.4 μ m (V)			
	Chip Size	5.79mm (H) x 4.89mm (V)			
Video output frequency	60fps Mode	Pixel Clock	24.5454 MHz		
		Horizontal Frequency	31.468 kHz Pixel Clock 780 CLK		
	Vertical Frequency	Full Frame Scan Mode			
		Scanning lines	525 H	59.94 Hz	
		Binning Mode *1			
		Scanning lines	262.5 H	119.9 Hz	
	1/2 Partial Scan Mode				
		Scanning lines	262 H	120.1 Hz	
		1/4 Partial Scan Mode			
		Scanning lines	131 H	240.2 Hz	
	30fps Mode	Pixel Clock	12.2727 MHz		
		Horizontal Frequency	15.734kHz Pixel Clock 780 CLK		
		Vertical Frequency	Full Frame Scan Mode		
			Scanning lines	525 H	29.97 Hz
Binning Mode *1					
Scanning lines			262.5 H	59.94 Hz	
1/2 Partial Scan Mode					
		Scanning lines	262 H	60.05 Hz	
1/4 Partial Scan Mode					
Scanning lines		131 H	120.1 Hz		
*1 At normal operation, the camera functions as 2:1 interlaced scan mode.					
Sync. system	Internal sync & HD/VD external sync (Internal/External recognized automatically)				
Video output standard	Analog				
Resolution	480 TV lines				
Sensitivity	F5.6 400 lx (60fps: Shutter speed 1/60s, Gain 0dB, 3200K)				
Minimum illumination	F1.4 1.5 lx (60fps: Shutter speed 1/60s, max Gain VS 50IRE)				
S/N ratio	56dB				
Dust or stains in optical system	No dust or stain shall be detected on the testing screen with setting the camera aperture at F16.				

Item	Specification		
Power requirements	DC +12V \pm 10% (Max voltage not to exceed 15V)		
Power consumption	1.6 W typ (max. 2W) at DC +12V IN		
Dimension	Refer to overall dimension drawing (Clause 9) 29mm x 29mm x 29mm (excluding projection)		
Mass	Approx. 45 g		
Lens mount	C mount (Refer to overall dimension drawing)		
Optical axis accuracy	Refer to drawing for CCD Optical Axis Accuracy (Clause 8)		
Gain variable range	0~12dB (guaranteed range)		
Gamma	1 (fixed)		
Shutter speed variable range	Switch: 60fps Mode: OFF(1/60), 1/200, 1/500, 1/1000, 1/2000, 1/4000, 1/8000, 1/20000s 30fps Mode: OFF(1/30), 1/100, 1/250, 1/500, 1/1000, 1/2000, 1/4000, 1/10000s Pulse Width: 10 μ ~250ms		
Operation Mode	Fixed Trigger Shutter Mode (Exposure time can be set with rear switch). Pulse Width Trigger Shutter Mode (Exposure time can be set with trigger pulse width.)		
Safety/Quality standards	UL: Conform to UL Standard including materials and others. RoHS: Conform to RoHS CE: Conform to EN55022:2006 (Class B): Emission Conform to EN61000-6-2:2005: Immunity Conform to FCC Class A digital Device This device complies with Part 15 of the FCC Rules. Operation is subject to the following two conditions: (1) this device may not cause harmful interference, and (2) this device must accept any interference received, including interference that may cause undesired operation.		
Durability	Vibration	Acceleration	98 m/s ² (10.0G)
		Frequency	20~200 Hz
		Direction	XYZ 3 directions
		Testing time	120 min for each direction
	Shock	No malfunction shall be occurred with 980m/s ² (100G) for \pm X, \pm Y, \pm Z, 6 directions. (without package)	
Operation environment	Temperature	Operation guaranteed: -5°C~+45°C Performance guaranteed: 0°C~+40°C	
	Humidity	RH 20~80% with no condensation	
Storage environment	Temperature	-25°C ~ +60°C	
	Humidity	RH 20~80% with no condensation	

4.2. Camera Input/Output Signal Specification

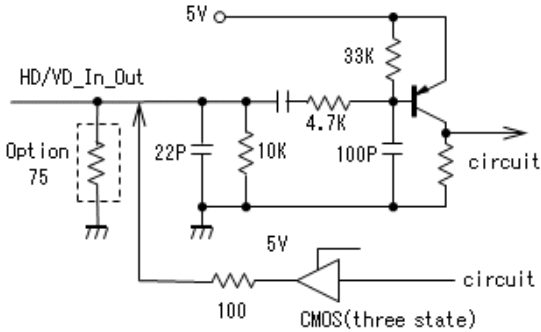
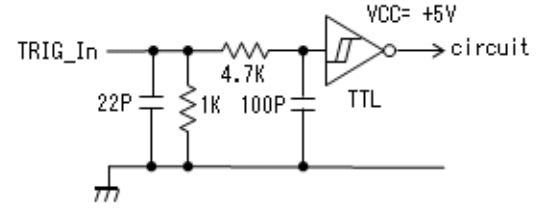
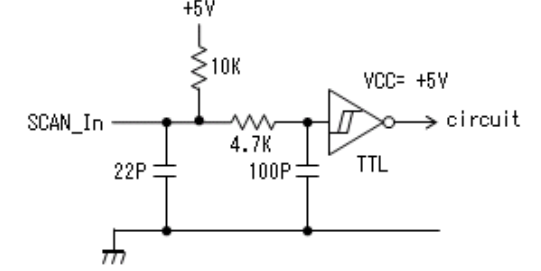
Item	Specification
Video output	Effective output: 648(H) × 494(V) at full frame scan mode
Sync signals Input /Output	<p>HD/VD Input signal level: 2~5Vp-p Input impedance: 10kΩ. 75 Ω can be set as an optional factory setting. Allowable frequency deviation: ±3% Phase difference: HD/VD: under 0±5μs Jitter: under 20ns</p>  <p>HD/VD/WEN output CMOS (74VHC04 equivalent) Output impedance 100Ω HD/VD/WEN output signal level Low 0.5V (max), High 4V (Min)</p>
Trigger input	<p>Polarity: Positive Input signal level: Low 0.5V (max), High 2.5~5V Input impedance: 1kΩ Trigger input width: 4μs ~ 250ms</p> 
Scan IN input 9 pins scan select	<p>Input signal level: Low 0.5V (max) High 2.5~5V Input impedance: 10kΩ (Pull Up)</p> 
Video signal	<p>VS output 1.0V (p-p), Sync. Negative, 75Ω unbalanced, DC connect White clip level: 840 ± 70 mVp-p Setup level: 25 ± 15 mVp-p (Gain 0dB) SYNC level: 290 ± 50 mVp-p VS DC level: 0 ± 100 mV</p>

4.3. CCD Spectral Response (Representative value)

※ Lens characteristics and illuminant characteristics are not considered.

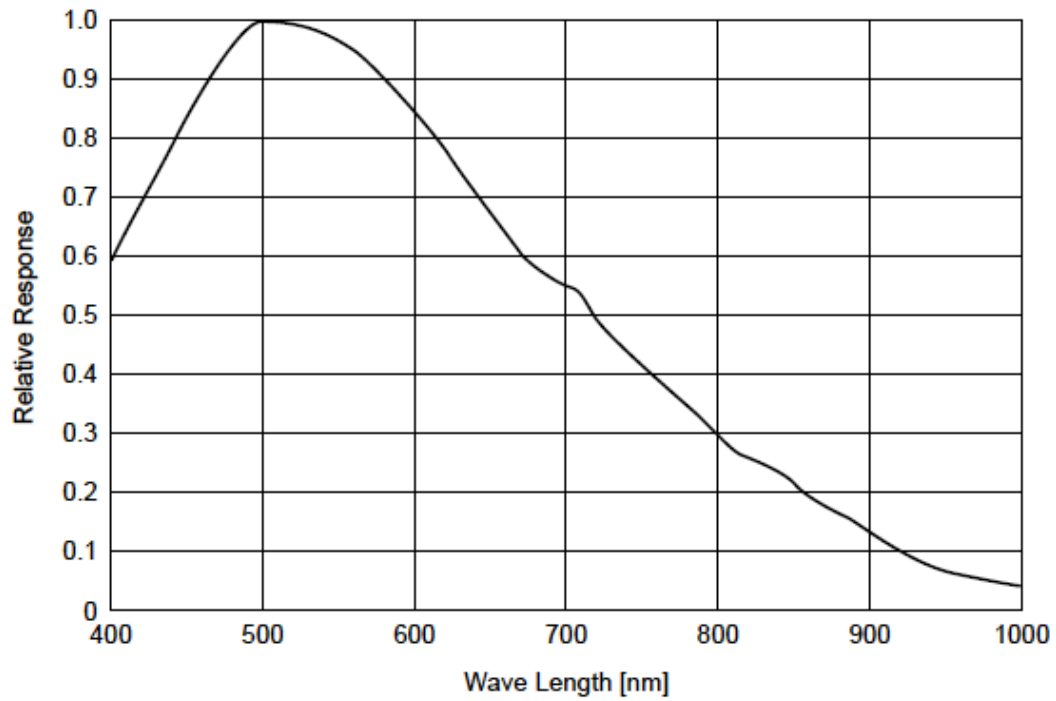

5. Function Settings

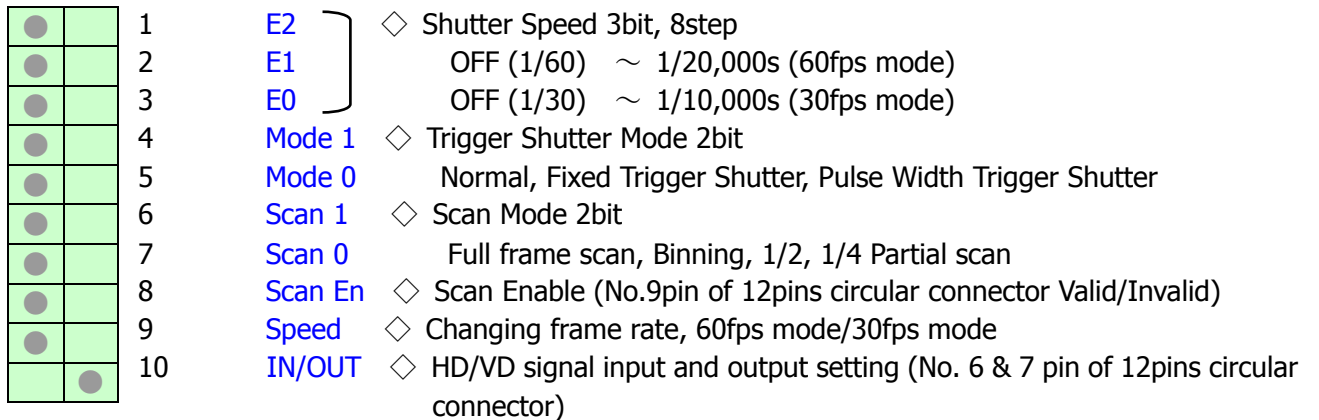

↑
OFF

● Indicates initial setting position.

Other Optional Functions (Ex-factory setting)

- ◇ HD/VD75Ω impedance
 - ◇ $\gamma = 0.45$ compensation
- Please ask us for the details.

Shutter Speed Settings

E2	E1	E0	Shutter Speed	Actual Time	
SW1	SW2	SW3		Normal	Trigger
OFF	OFF	OFF	OFF(1/60s)	16.67 ms	8.33 ms
OFF	OFF	ON	1/200 sec	5.0 ms	5.0 ms
OFF	ON	OFF	1/500 sec	2.0 ms	2.0 ms
OFF	ON	ON	1/1000 sec	1.0 ms	1.0 ms
ON	OFF	OFF	1/2000 sec	490 μs	495 μs
ON	OFF	ON	1/4000 sec	240 μs	243 μs
ON	ON	OFF	1/8000 sec	113 μs	116 μs
ON	ON	ON	1/20000 sec	51 μs	52 μs

※ Shutter speed and actual time shown above is for 60fps mode. With 30fps mode, the actual time will be double.

■ Indicates initial setting position

Operational Mode Settings

MODE1	Mode0	Setting Mode
SW4	SW5	
OFF	OFF	Normal Shutter Mode (including Restart-Reset Operation)
OFF	ON	Fixed Trigger Shutter Mode (Sync Reset Type)
ON	OFF	Pulse Width Trigger Shutter Mode 1 (Sync Reset Mode)
ON	ON	Pulse Width Trigger Shutter Mode 2 (Sync Non-Reset Mode)

■ Indicates initial setting position

Table of Settings

Function \ Shutter Mode	Normal Shutter Mode	Fixed Trigger Shutter Mode (Sync Reset)	Pulse width trigger Shutter Mode 1 (Sync Reset)	Pulse width trigger Shutter Mode 2 (Sync Non-reset)
Shutter speed by switch	○※1	○	×	×
Shutter speed by pulse width	×	×	○	○
Full Frame Scan	○	○	○	○
Binning Scan	○※2	○	○	○
Partial Scan	○	○	○	○
HD/VD Input	○	○HD	○HD	○
HD/VD Output	○	○	○	×

※1 When using the camera with Restart-Reset Mode, shutter speed setting switch shall be OFF.

※2 2:1 interlaced scan can be valid but restart-reset mode cannot be operated at normal shutter mode.

Normal Shutter Mode

Each scanning mode and HD/VD external sync input and sync output are valid.

When adding external sync input, please follow the HD/VD input conditions shown below.

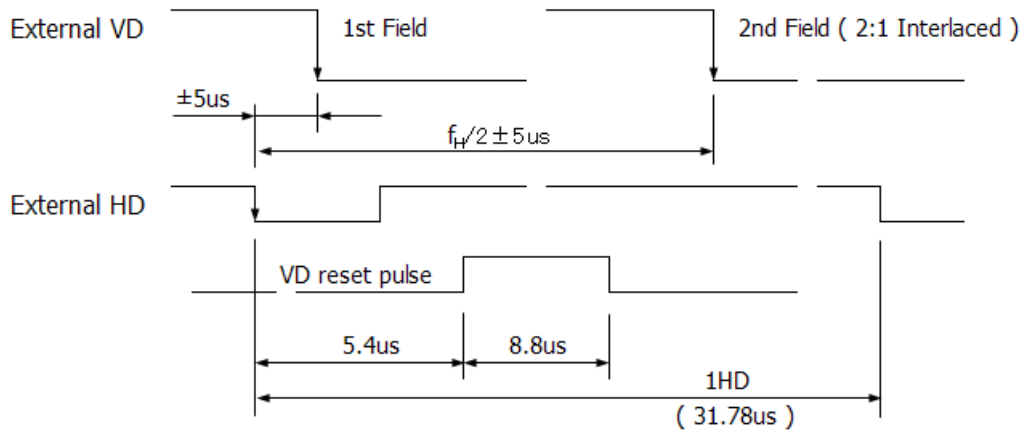

Restart-Reset Mode

Restart-reset mode (Long time exposure mode) is valid at normal mode, with setting the shutter to OFF, HD/VD sync input ON, and adding external EXT HD input. With adding EXT VD at random timing with over 1VD, data for one screen image is read out. This function is useful when sensitivity with regular exposure time is not sufficient or when indicating the locus of moving object. Restart-reset operation corresponds to all scanning modes except 2:1 interlaced scan mode.

Fixed Trigger Shutter Mode (Sync Reset Mode)

At fixed trigger shutter mode, exposure time is set by the shutter value of switch at camera rear. With trigger input, images can be captured at any timing.

Internal SYNC and VD are reset right after completion of exposure so that the video output signals are read out at the shortest timing. HD external input is valid but VD external input invalid.

Exposure time = Value of switch at rear

Conditions: Trigger input pulse width shall be $4\mu s \sim 250ms$, Positive Logic

The shortest trigger cycle = 1 frame + 5H

Pulse width trigger shutter mode 1 (Sync Reset Mode)

At pulse width trigger shutter mode, exposure time and shutter value can be set by trigger pulse width. With trigger input, images can be captured at any timing. Internal SYNC and VD are reset right after completion of exposure so that the video output signals are read out at the shortest timing. HD external input is valid but VD external input invalid.

Exposure time = Trigger pulse width (μs) + 5 μs typical
Conditions: Trigger input pulse width shall be 4 $\mu s \sim 250ms$, Positive Logic
The shortest trigger cycle = 1 frame + 5H

Pulse width trigger shutter mode 2 (Sync Non-Reset Mode)

At pulse width trigger shutter mode, exposure time and shutter value can be set by trigger pulse width. With trigger input, images can be captured at any timing. Signals are read out after waiting for the external VD (single) input so that the timing to read out video output signals can be controlled externally. The down edge phase of external HD/VD signals should be matched. The time frame between down edge of trigger input and to add single VD externally shall be set 10 $\mu \sim 35ms$.

Exposure time = Trigger pulse width (μs) + 5 μs typical
Conditions: Trigger input pulse width shall be 4 $\mu s \sim 250ms$, Positive Logic
The shortest trigger cycle = Trigger pulse width + VD waiting time + 1 frame + 2H

- Caution 1: When the next trigger is input before the completion of video signals output for the prior trigger, the images could be improper.
- Caution 2: Smear or blooming could occur when strong incident light is extensively illuminated, with setting the electric shutter at high speed. To avoid this smear or blooming, lower the volume of incident light or use a stroboscopic light source to control the light volume.
- Caution 3: Please refer to the exposure timing chart below for the actual timing to start exposure after adding trigger input, and or for the actual timing to complete exposure at pulse width trigger shutter operation.

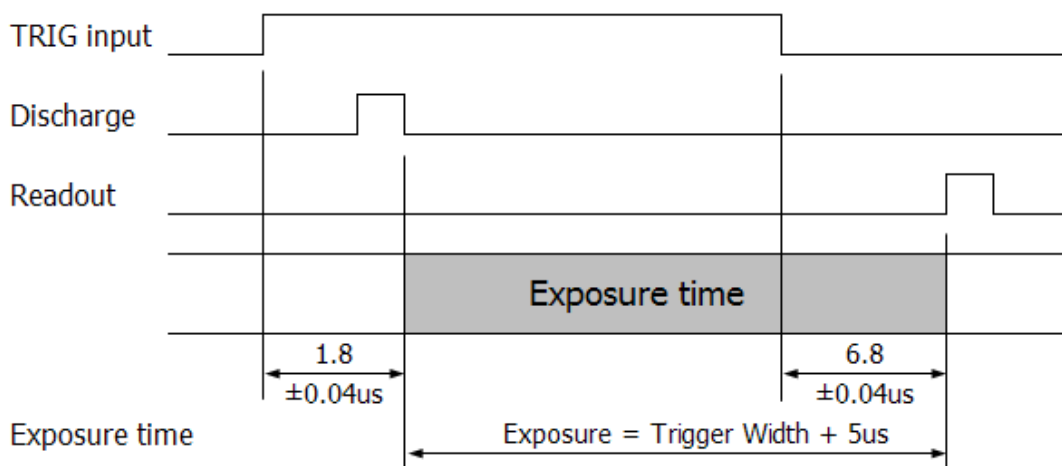

Scan Mode Settings

Scan 1	Scan 0	Setting Mode
SW6	SW7	
OFF	OFF	Full Frame Scan Mode
OFF	ON	Binning Mode or 2:1 Interlaced Scan Mode
ON	OFF	1/2 Partial Scan Mode
ON	ON	1/4 Partial Scan Mode

When setting scan mode with No.9pin of 12pins circular connector

SW8	OFF	No.9pin invalid	(Pull Up 10kΩ)
	ON	No.9pin valid	Low Level

Indicates initial setting position

Scan modes set by SW6 and SW7

Scan Mode	Frame Rate (fps)	Scanning lines (Lines)	Blanking Lines (Lines)	Video output lines (Lines)
Full Frame Scan Mode	59.94	525	23	494
Binning Mode	119.9	262.5	20	242.5
1/2 Partial Scan Mode	120.1	262	32	222
1/4 Partial Scan Mode	240.2	131	38	76

The value shown above is for 60fps mode setting.

Changing the scan settings

Scan settings shall be changed basically by the settings of camera switch at rear, but it can be also changed by the input level of No. 9pins of the circular connector at both Normal shutter mode and Trigger shutter mode.

- ① Set SW 8 ON at camera rear to enable No. 9 pins input of the circular connector.
- ② Select Binning Mode or Partial Scan Mode with SW 6 and 7 at camera rear.
- ③ Change H/L input level of No. 9 pins of the circular connector.

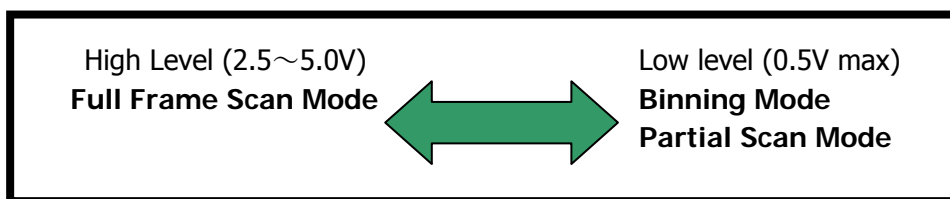

Changing frame rate settings

SW9	OFF	60fps Mode	Pclk=24.545MHz
	ON	30fps Mode	Pclk=12.272MHz

※ Reboot the camera to change the pixel clock.

Changing HD/VD input and output

SW10	OFF	HD/VD output
	ON	HD/VD input

Indicates the factory setting position

6. External Connector Pin Assignment

6.1. 12 pins Circular Connector SNH-10-12 (RPCB) (SAMWOO)

Pin No.	
1	GND
2	Power In DC+12V
3	GND
4	Video Out
5	GND
6	HD In/Out
7	VD In/Out
8	GND
9	Scan In
10	WEN Out
11	Trig In
12	GND

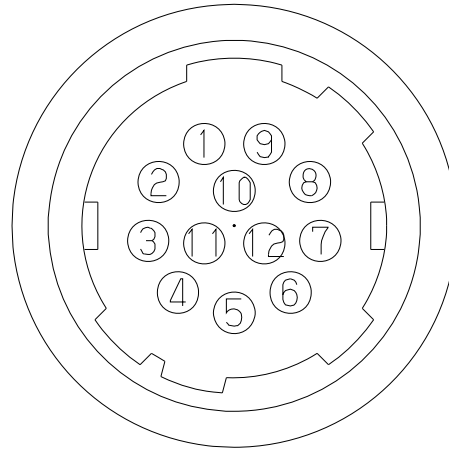

7. Timing Chart

7.1. Horizontal Sync Timing

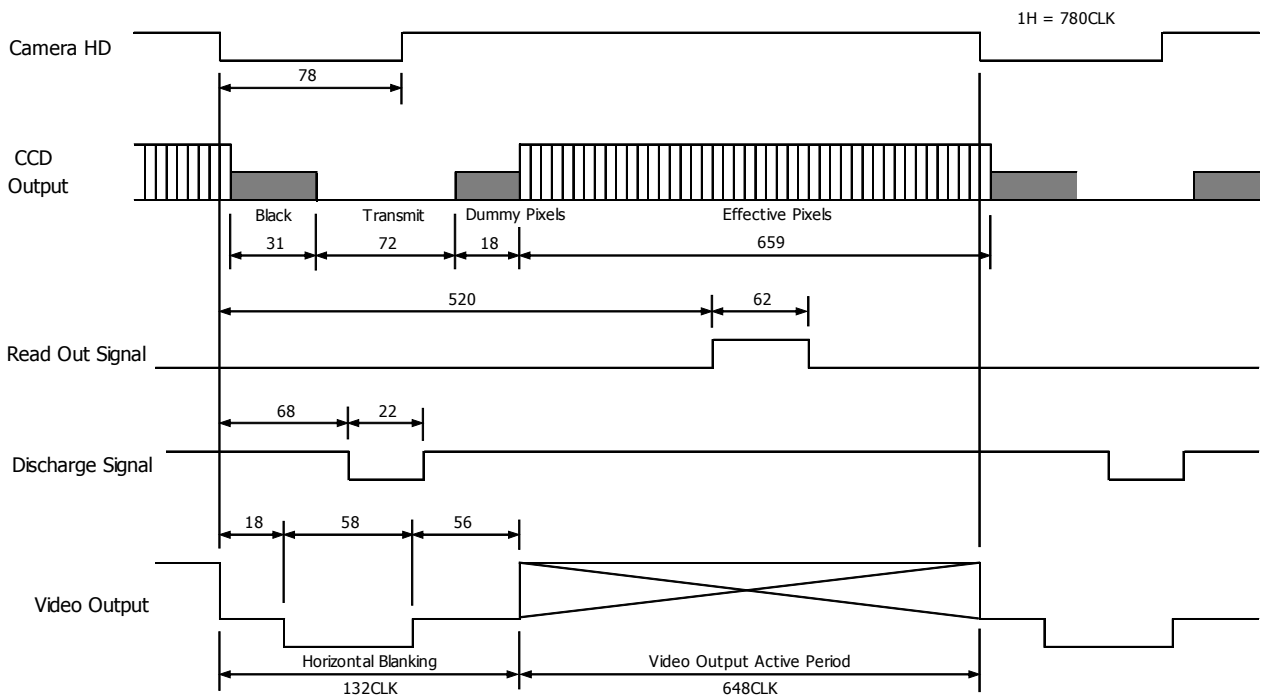

7.2. Vertical Sync Timing

7.2.1. Full Frame Scan Mode

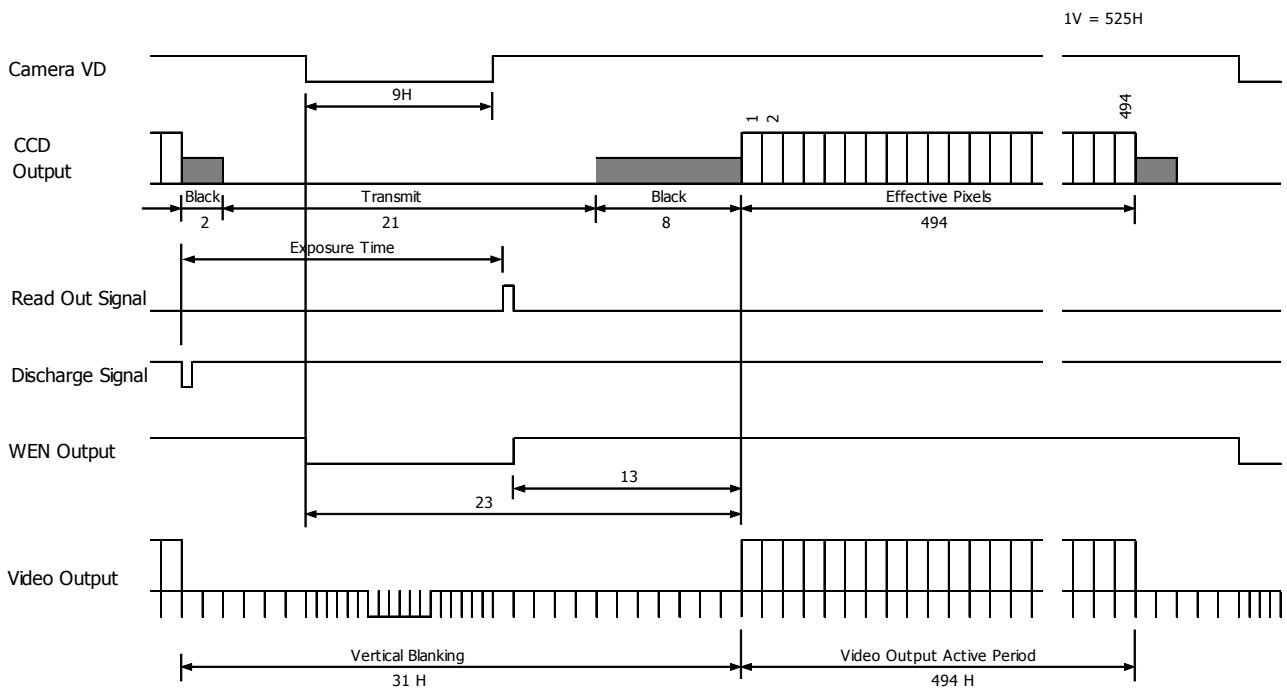

7.2.2. 2:1 Interlaced Scan Mode (At Normal Shutter Mode)

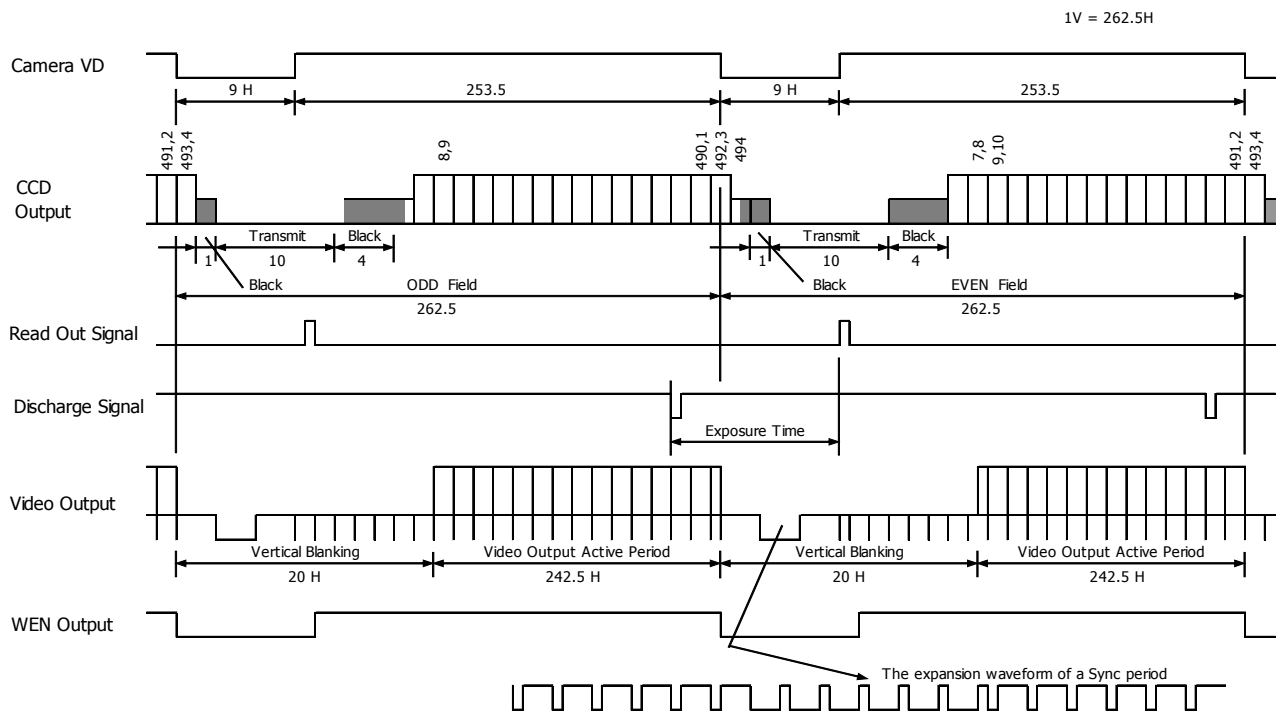

7.2.3. Binning Mode (At Trigger Shutter Mode)

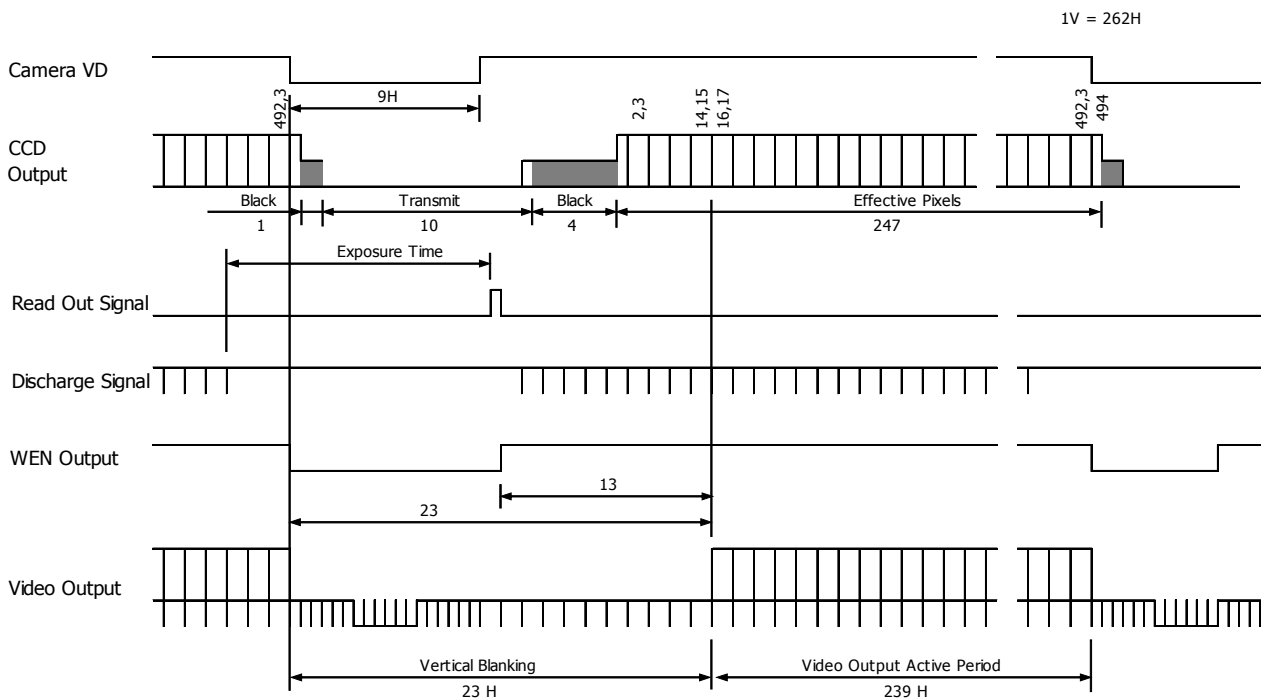

7.2.4. 1/2 Partial Scan Mode

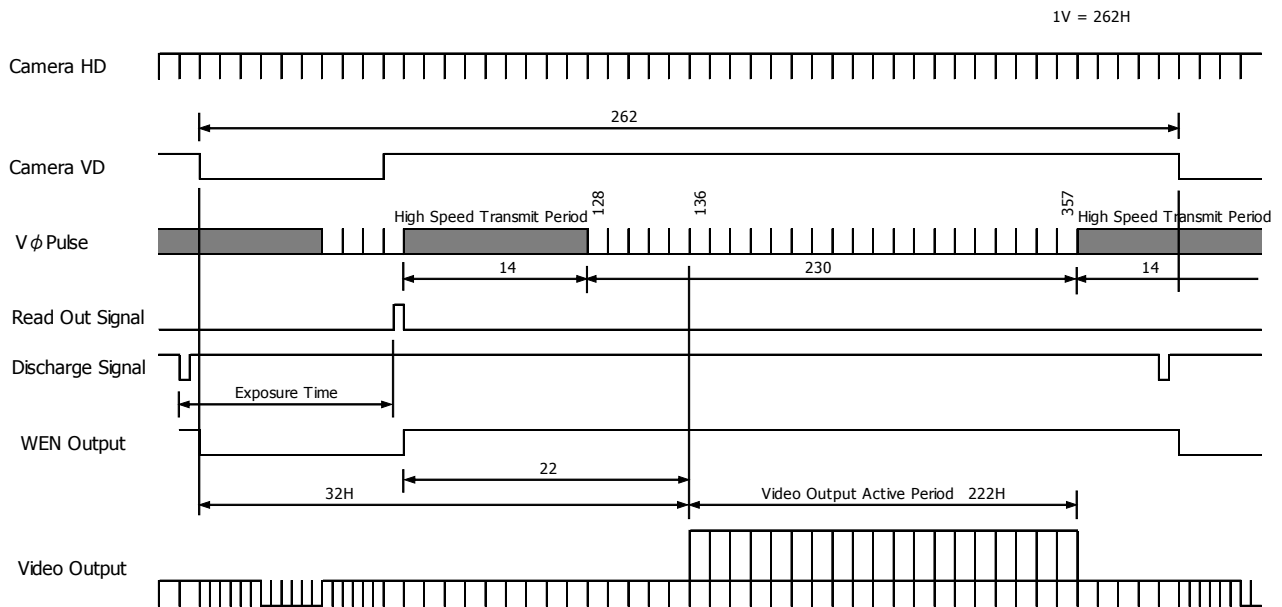

7.2.5. 1/4 Partial Scan Mode

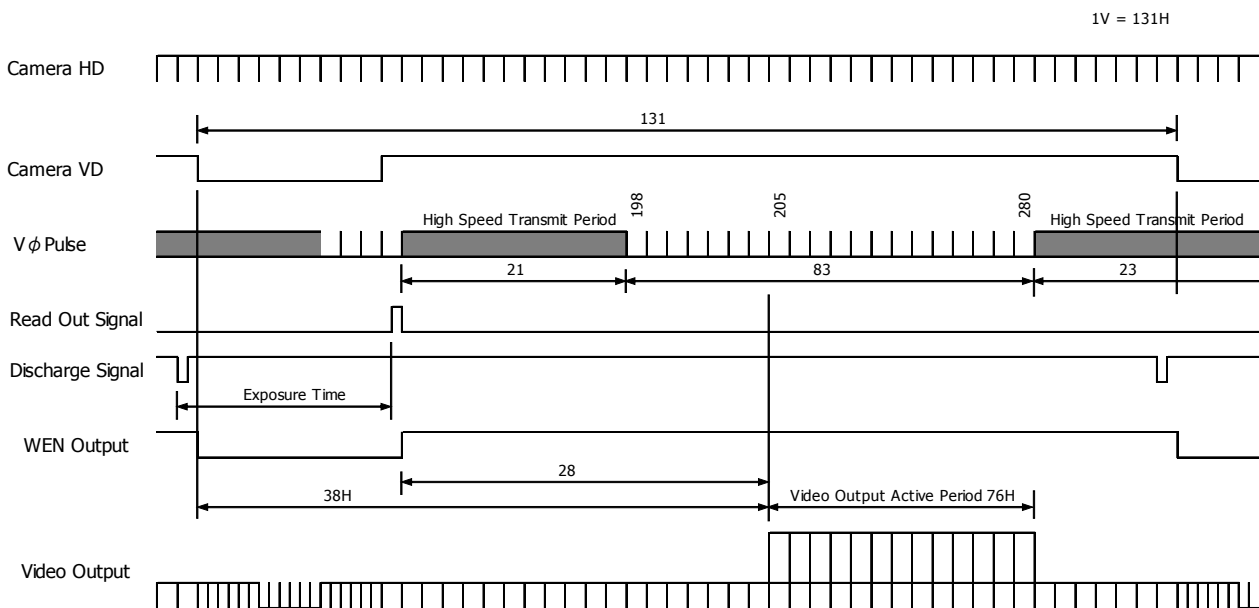

7.3. Restart-Reset Mode (Long Time Exposure) Timing

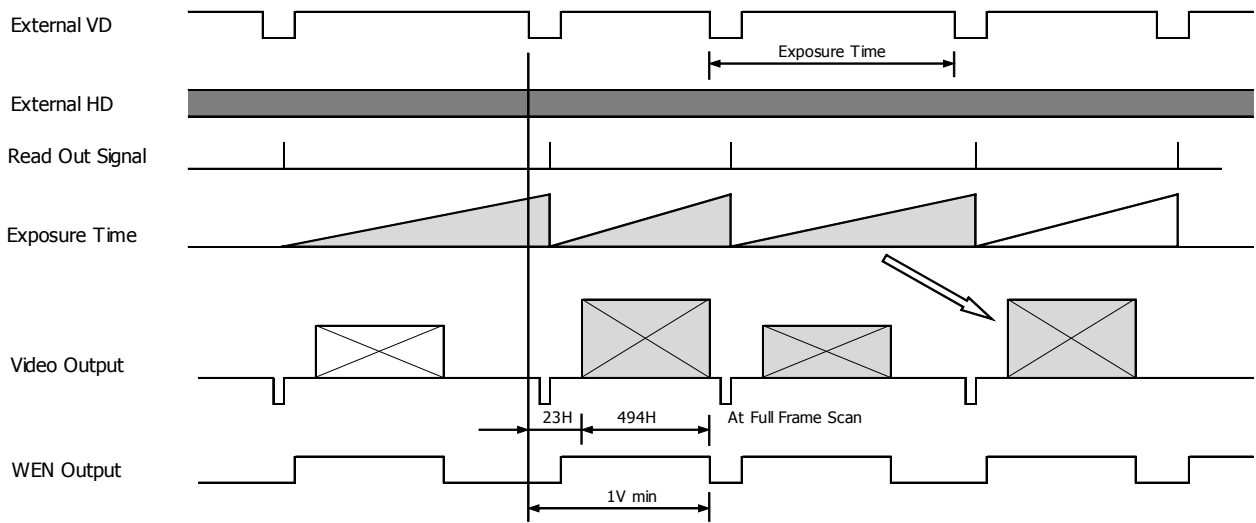

7.4. Trigger Shutter Mode Timing

7.4.1. Fixed Trigger Shutter Mode (Sync Reset)

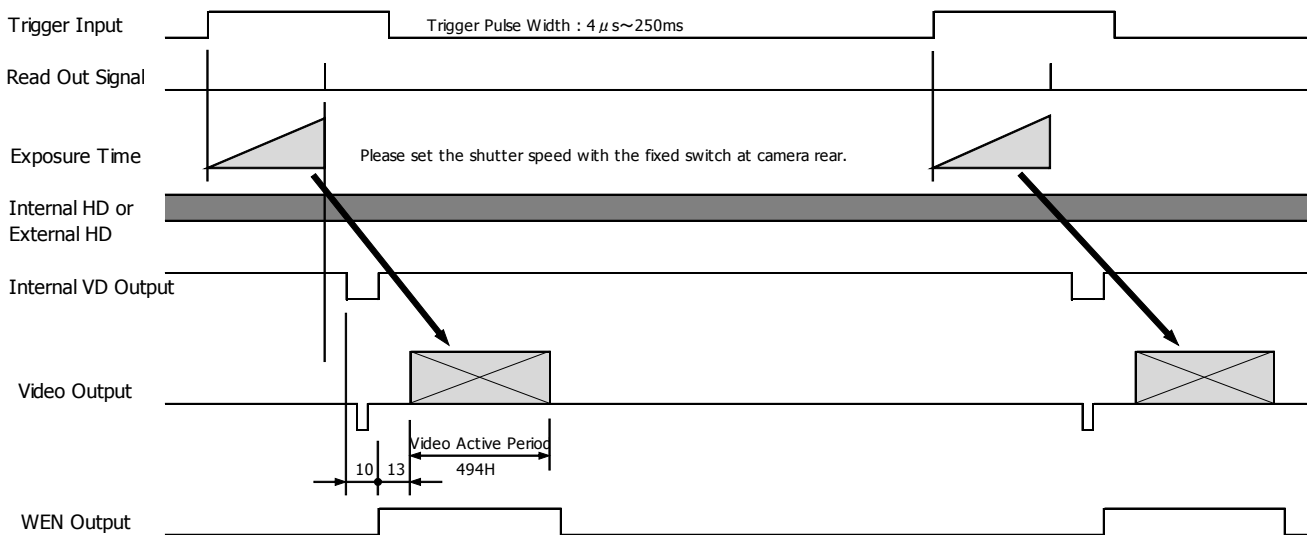

7.4.2. Pulse Width Trigger Shutter Mode 1 (Sync Rese)

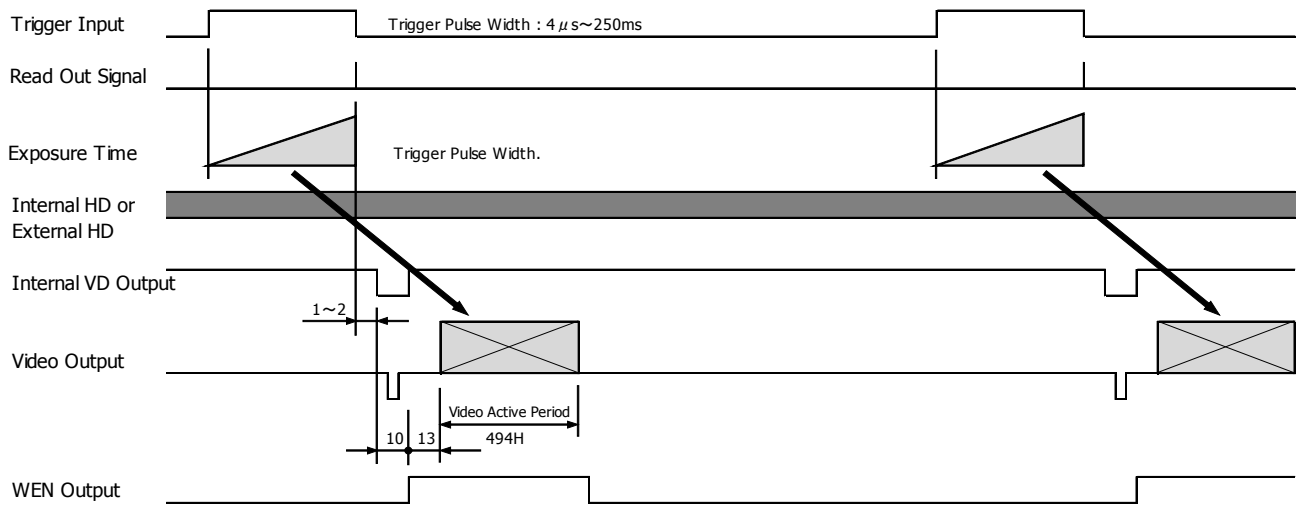

7.4.3. Pulse Width Trigger Shutter Mode 2 (Sync Non-Reset)

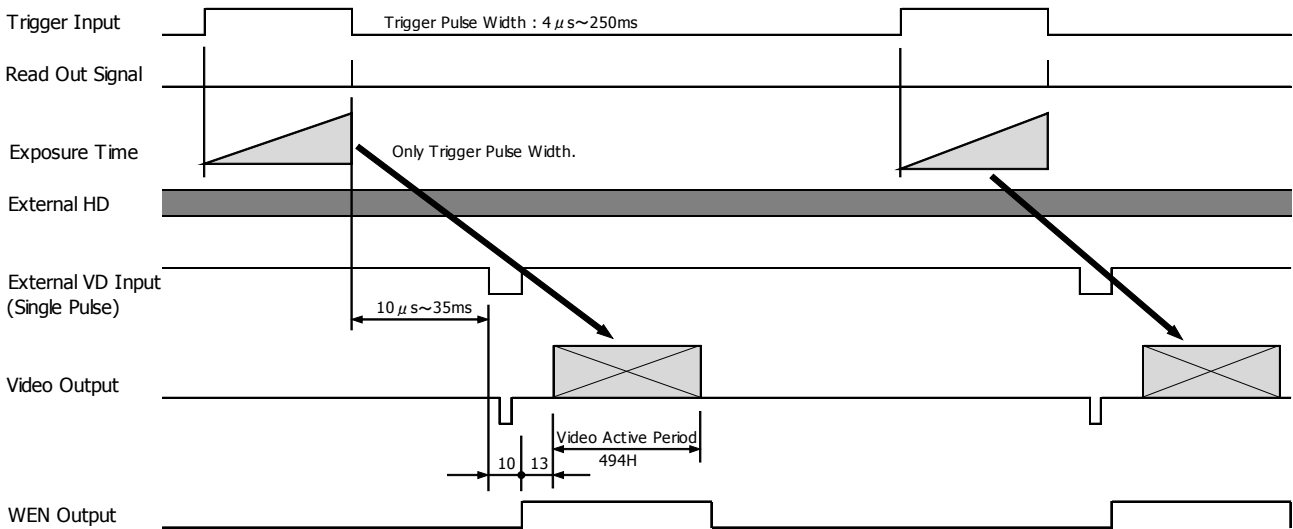

8. CCD Optical Axis Accuracy

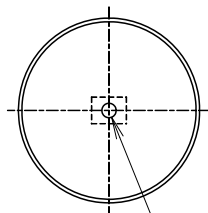
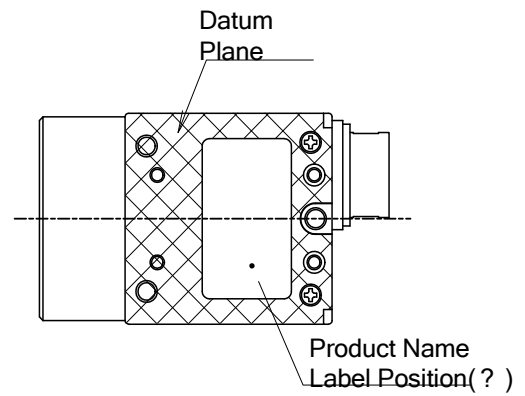
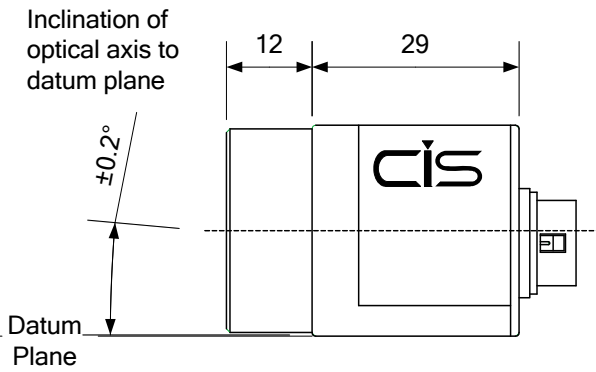
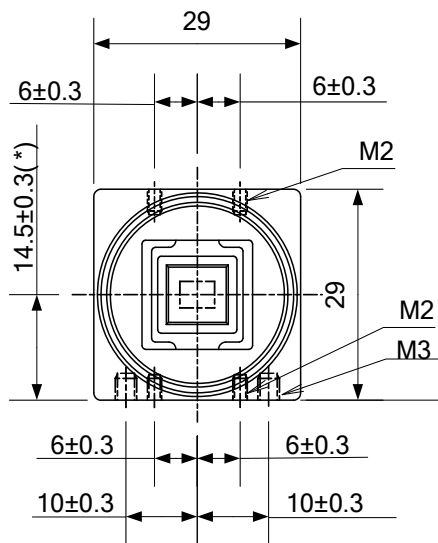

The center of effective pixels shall be within $f 0.6$ to the center of lens mount.

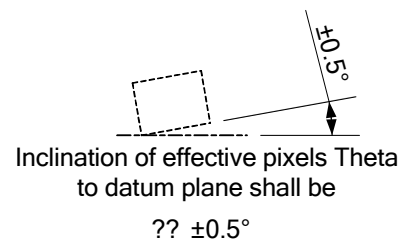

(*) Dimension from datum plane to the center of lens mount.

910-005-00-00
(Unit : mm)

9. Dimensions

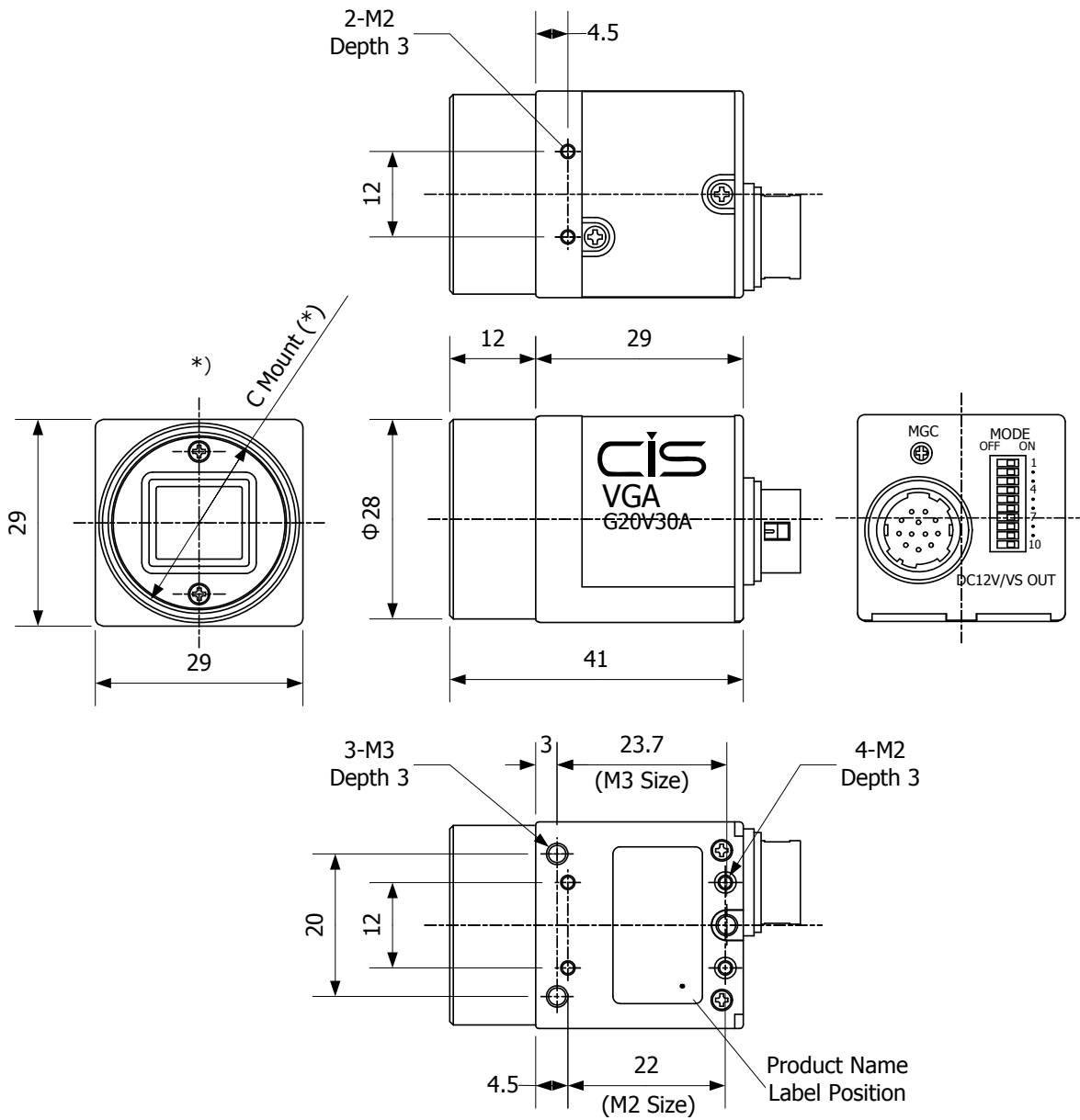

*) C Mount screws comply with ANSI/ASME B1.1, 1-32UN(2B).
*) Screw length from C mount lens surface shall be under 6mm.
And protruding portion shall be less than 10mm.

999-488-00-00

(Unit:mm)

10. Cases for Indemnity (Limited Warranty)

We shall be exempted from taking responsibility and held harmless for damage or losses incurred by the user in the following cases.

- ✧ In case damage or losses are caused by fire, earthquake, or other acts of God, acts by third party, deliberate or accidental misuse by the user, or use under extreme operating conditions.
- ✧ In case indirect, additional, consequential damages (loss of business interests, suspension of business activities) are incurred as result of malfunction or non-function of the equipment, we shall be exempted from responsibility for such damages.
- ✧ In case damage or losses are caused by failure to observe the information contained in the instructions in this product specification & operation manual.
- ✧ In case damage or losses are caused by use contrary to the instructions in this product specification & operation manual.
- ✧ In case damage or losses are caused by malfunction or other problems resulting from use of equipment or software that is not specified.
- ✧ In case damage or losses are caused by repair or modification conducted by the customer or any unauthorized third party (such as an unauthorized service representative).
- ✧ Expenses we bear on this product shall be limited to the individual price of the product.

11. CCD Pixel Defect

After delivery, CCD pixel defects might be noted with time of usage of the products.

The cause of the CCD pixel defects is the characteristic phenomenon of CCD itself and CIS shall be exempted from taking responsibility on it.

12. Product Support

When defects or malfunction of our products occur, and if you would like us to investigate on the cause and repair, please contact your distributors you purchased from to consult and coordinate.