



English

**VISION:analog™**

**XGA Color Analog Camera**

**VCC-F40X34**

**Product Specification**  
**& Operational Manual**

**CIS Corporation**

## Table of Contents

1. Scope of Application.....	3
2. Handling Precautions .....	3
3. Product Outline.....	4
4. Specification.....	5
4.1. General Specification .....	5
4.2. Camera Output Signal Specification.....	7
4.3. CCD Spectral Response (Representative value).....	8
5. Function Settings.....	9
6. External Connector Pin Assignment .....	11
7. Timing Chart.....	12
7.1. Horizontal Synchronous Timing Chart .....	12
7.2. Vertical Synchronous Timing Chart .....	12
7.3. Fixed Trigger Shutter Operation (SYNC Reset Type) .....	13
7.4. Pulse Width Trigger Operation (SYNC Rest Type) .....	13
8. Remote Interface Function.....	14
9. Initial Settings .....	15
10. CCD Optical Axis Accuracy .....	16
11. Dimensions.....	17
12. Cases for Indemnity (Limited Warranty).....	18
13. CCD Pixel Defect .....	18
14. Product Support.....	18

## 1. Scope of Application

This is to describe VCC-F40X34 analog color CCD Camera. All specifications contained herein are subject to change without prior notice. Reproduction in whole or in part is prohibited.

## 2. Handling Precautions

The camera must not be used for any nuclear equipments or aerospace equipments with which mechanical failure or malfunction could result in serious bodily injury or loss of human life. Our warranty does not apply to damages or defects caused by irregular and/or abnormal use of the product.

Please observe all warnings and cautions stated below.

Our warranty does not apply to damages or malfunctions caused by neglecting these precautions.

- Do not use or store the camera in the following extreme conditions:
  - Extremely dusty or humid places.
  - Extremely hot or cold places (operating temperature  $-5^{\circ}\text{C}$  to  $+45^{\circ}\text{C}$ )
  - Close to generators of powerful electromagnetic radiation such as radio or TV transmitters.
  - Places subject to fluorescent light reflections.
  - Places subject to unstable (flickering, etc.) lighting conditions.
  - Places subject to strong vibration.
- Remove dust or dirt on the surface of the lens with a blower.
- Do not apply excessive force or static electricity that could damage the camera.
- Do not shoot direct images that are extremely bright (e.g., light source, sun, etc.), and when camera is not in use, put the lens cap on.
- Follow the instructions in Chapter 6, "External connector pin assignment" for connecting the camera. Improper connection may cause damages not only to the camera but also to the connected devices.
- Confirm the mutual ground potential carefully and then connect the camera to monitors or computers. AC leaks from the connected devices may cause damages or destroy the camera.
- Do not apply excessive voltage. (Use only the specified voltage.) Unstable or improper power supply voltage may cause damages or malfunction of the camera.

- The voltage ripple of camera power DC  $+12V \pm 10\%$  shall be within  $\pm 50mV$ . Improper power supply voltage may cause noises on the video signals.
- The rising time of camera power supply voltage shall be less than  $+10V$ , Max 60ms. Please avoid noises like chattering when rising.

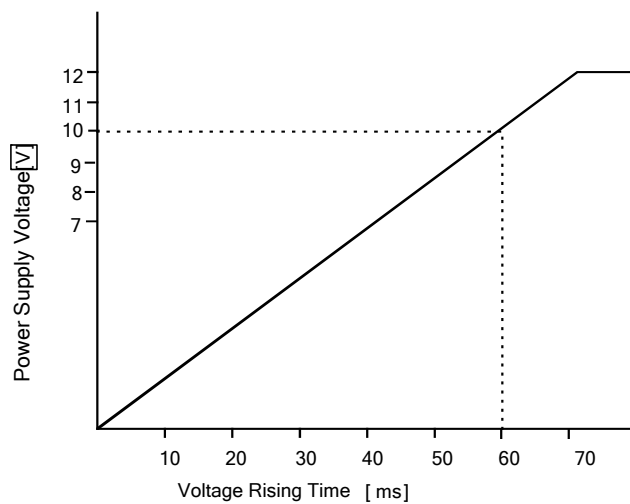

### 3. Product Outline

VCC-F40X34 is a high-resolution industrial color analog camera module utilizing a 1/3 type PS IT CCD. 800K pixels CCD image sensor with on-chip micro-lenses realizes high sensitivity and high resolution. At Full Frame Scan Mode, entire pixels can be read out within approx. 1/30s. VCC-F40X34 is an analog interfaced camera. As an optional component parts, 12pins connector for power supply, HR10-10R012SA (HIROSE), can be enclosed. Please ask for the details.

## 4. Specification

## 4.1. General Specification

Item	Specification	
Pickup device	Device Type	1/3 type Interline Transfer color CCD, Sony ICX204AK
	Effective Pixel Number	1034(H) x 779 (V)
	Unit Cell Size	4.65 $\mu$ m (H) x 4.65 $\mu$ m (V)
	Chip Size	5.80mm (H) x 4.92mm (V)
Video output frequency	Pixel Clock	30.0000 MHz
	Horizontal Frequency	23.622 kHz Pixel Clock 1270 CLK
	Vertical Frequency	1/30s Full Frame Scan Mode Scanning lines 792 H 29.825 Hz
Sync. system	Internal sync & HD/VD external sync	
Video output standard	Analog RGB	
Resolution	520 TV lines	
Sensitivity	F 5.6 2000 lx (Shutter 1/30s, Gain 0dB, 3200K)	
Minimum illumination	F1.4 25 lx (Shutter 1/30s, max Gain VS 50IRE)	
Dust or stains in optical system	No dust or stain shall be detected on the testing screen with setting the camera aperture at F16.	
Power requirements	DC +12V $\pm$ 10% (Max voltage not to exceed 15V)	
Power consumption	2.8 W (at DC +12V IN)	
Dimension	Refer to overall dimension drawing (Clause 11) 44mm x 44mm x 77mm (excluding projection)	
Mass	Approx. 170 g	
Lens mount	C mount (Refer to overall dimension drawing)	
Optical axis accuracy	Refer to drawing for CCD Optical Axis Accuracy (Clause 10)	
Gain variable range	0~12dB (guaranteed range)	
Trigger Mode	<ul style="list-style-type: none"> <li>• Fixed Shutter Trigger Operation</li> <li>• Pulse Width Trigger Operation</li> </ul>	
Shutter speed variable range	1/30 (OFF), 1/60, 1/100, 1/120, 1/250, 1/500, 1/1000, 1/2000, 1/4000, 1/10000s Shutter speed set by trigger pulse width: 1/4~1/10000s (per 1H)	

Item	Specification		
Safety/Quality standards	UL: Conform to UL Standard including materials and others. RoHS: Conform to RoHS CE: Conform to EN55022:2006 (Class B): Emission Conform to EN61000-6-2:2005: Immunity FCC: To be applied		
Durability	Vibration	Acceleration	98 m/s <sup>2</sup> (10.0G)
		Frequency	20~200 Hz
		Direction	XYZ 3 directions
		Testing time	120 min for each direction
	Shock	No malfunction shall be occurred with 980m/s <sup>2</sup> (100G) for ±X, ±Y, ±Z, 6 directions. (without package)	
Operation environment	Temperature	Operation guaranteed: -5°C~+45°C Performance guaranteed: 0°C~+40°C	
	Humidity	RH 20~80% with no condensation	
Storage environment	Temperature	-25°C ~ +60°C	
	Humidity	RH 20~80% with no condensation	

4.2. Camera Output Signal Specification

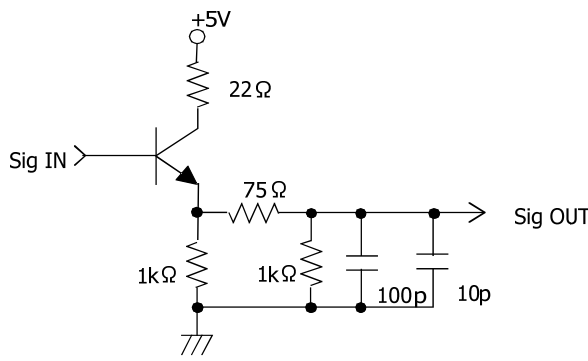
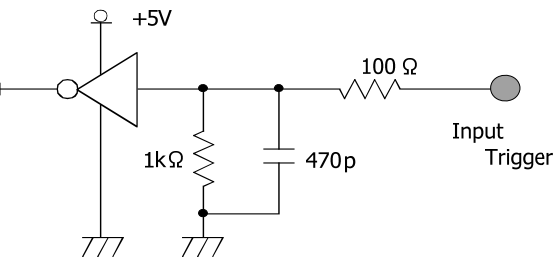
Video output	Effective output 1024(H) × 768(V) at full frame scan mode
Sync signals Input /Output	Input signal level: 2~5Vp-p, TTL input Automatically switched by HD recognition. Allowable frequency deviation: ±1% HD/VD/WEN/SYNC output 2~5.0V Negative polarity output 
Trigger input	Polarity: Trigger Positive/Negative selectable with address 005. Trigger input width: Min. 2H and over TTL Input Refer to the below.  VIH Min 4.0V VIL Max 0.5V
Video signal	VS output 1.0V (p-p), Sync. Negative, 75Ω unbalanced, DC connect White clip level: 840 ± 40 -30mVp-p (Excluding SYNC) Setup level: 25 ± 10 mVp-p (Excluding SYNC) SYNC level: 280 ± 30 mVp-p RGB DC level: 290 ± 100 mV

## 4.3. CCD Spectral Response (Representative value)

※ Lens characteristics and illuminant characteristics are not considered.

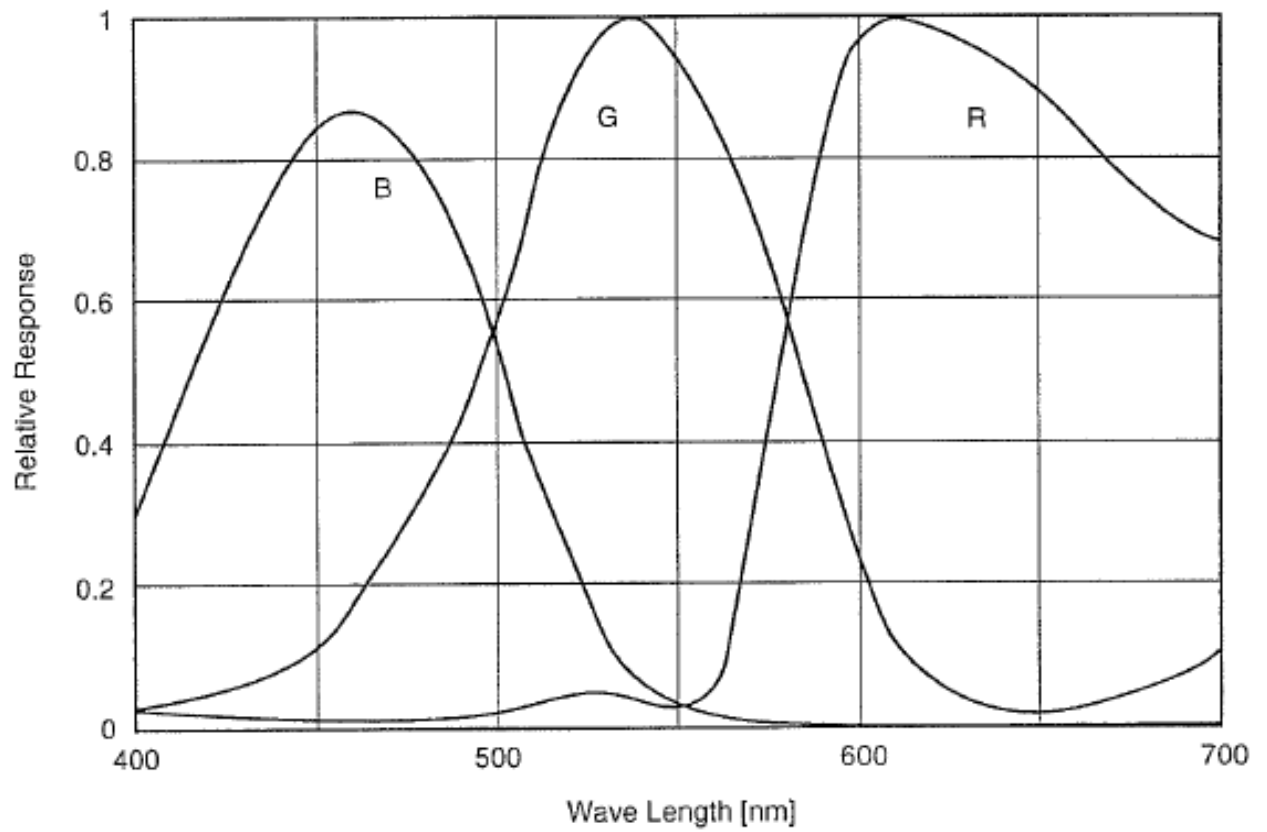



Functions	Address	Data
No Function	013	0: Do not change
Trigger Reset Mode	014	0: H- Synchronous Mode
		1: CLK- Synchronous Mode
	015~062	Do not change the data in this area, otherwise, the camera may not operate properly. If the data in this area is changed by mistake, please turn off the power once.
Data Save	063	Input 083 to save address 000~014 into EEPROM.

#### Fixed Shutter Trigger Mode

Fixed Shutter Trigger Mode is a trigger operation to set shutter value (exposure time) with address 002. Trigger pulse width should be over 2H.

#### Pulse Width Trigger Mode

Pulse Width Trigger Mode is a trigger operation to set shutter value (exposure time) with trigger pulse width. Trigger pulse width should be within the range over 2H (1/10000s) to less than approx. 1/4s. Shutter can be controlled by 1H.

6. External Connector Pin Assignment

12 pins Circular Connector HR10-10R-12PA (HIROSE)

Pin No.	
1	GND
2	Power In DC+12V
3	GND
4	NA
5	GND
6	HD In/Out
7	VD In/Out
8	GND
9	NA
10	WEN Out
11	Trig In
12	GND

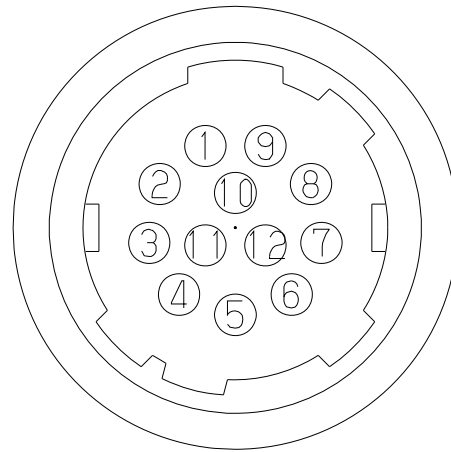

9 pins D-SUB Connector

Pin No.	
1	GND
2	GND
3	R OUT
4	G OUT
5	B OUT
6	NA
7	SYNC OUT
8	GND
9	GND

6 pins Circular Connector HR-10-7R-6PA

Pin No.	
1	RS232C TxD
2	RS232C RxD
3	GND
4	NA
5	NA
6	NA

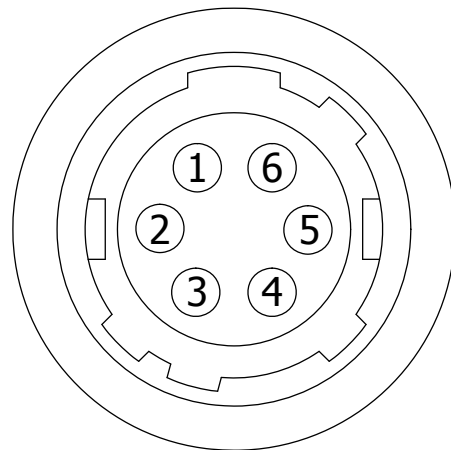

## 7. Timing Chart

### 7.1. Horizontal Synchronous Timing Chart

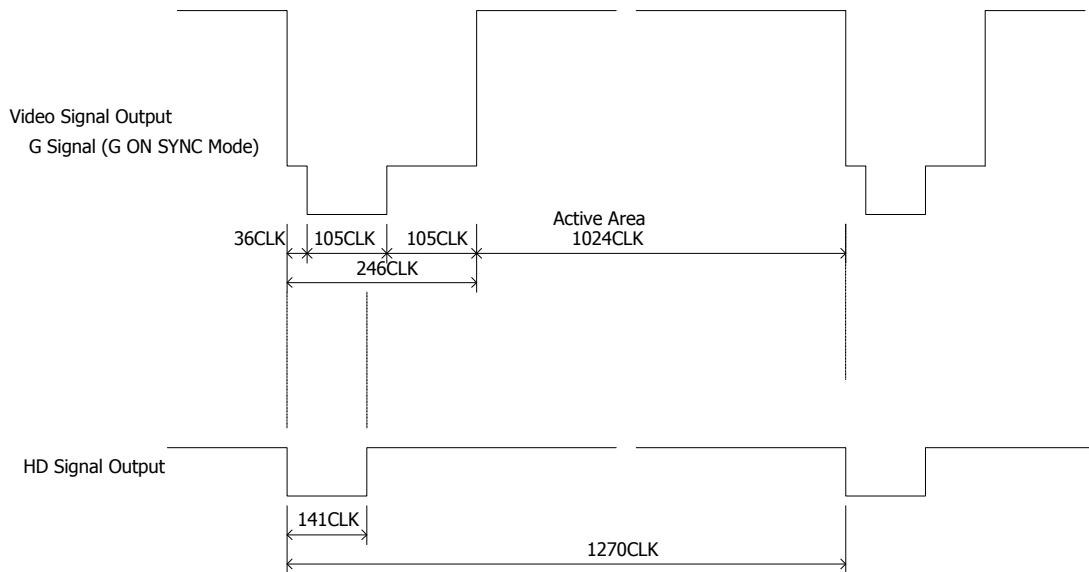

### 7.2. Vertical Synchronous Timing Chart

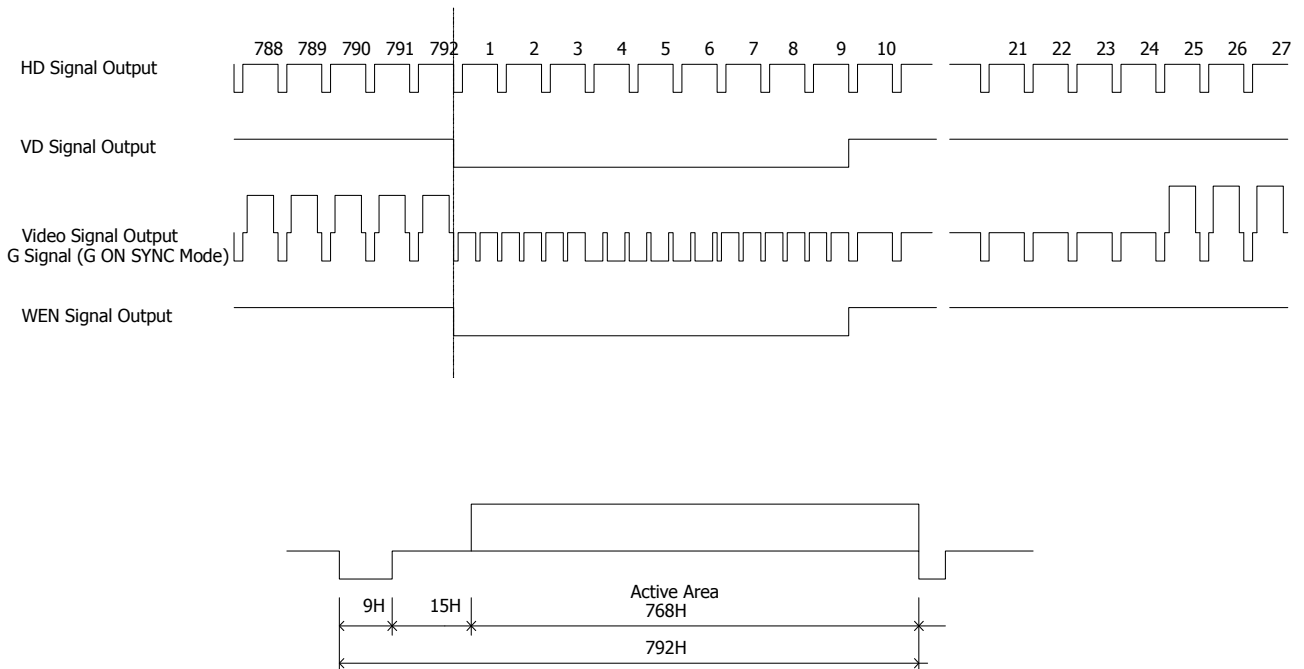

### 7.3. Fixed Trigger Shutter Operation (SYNC Reset Type)

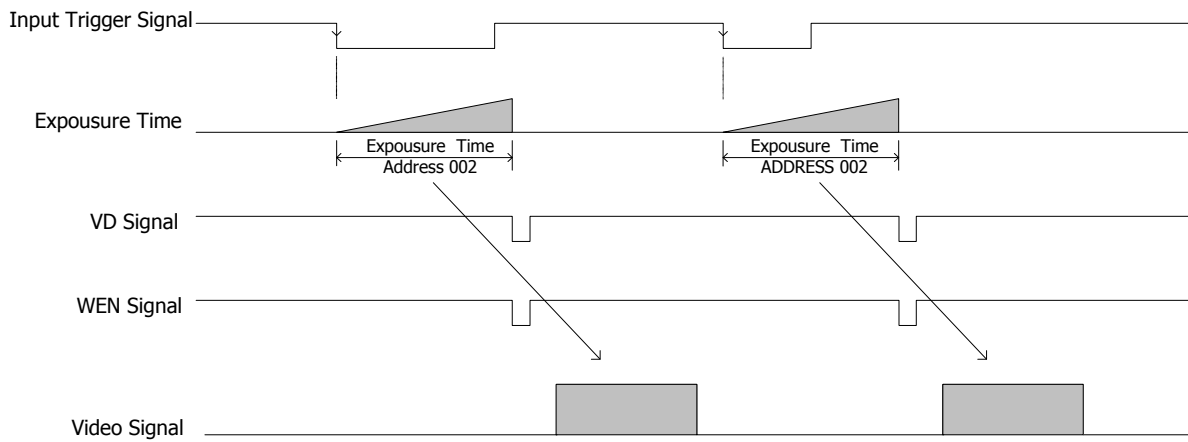

### 7.4. Pulse Width Trigger Operation (SYNC Rest Type)

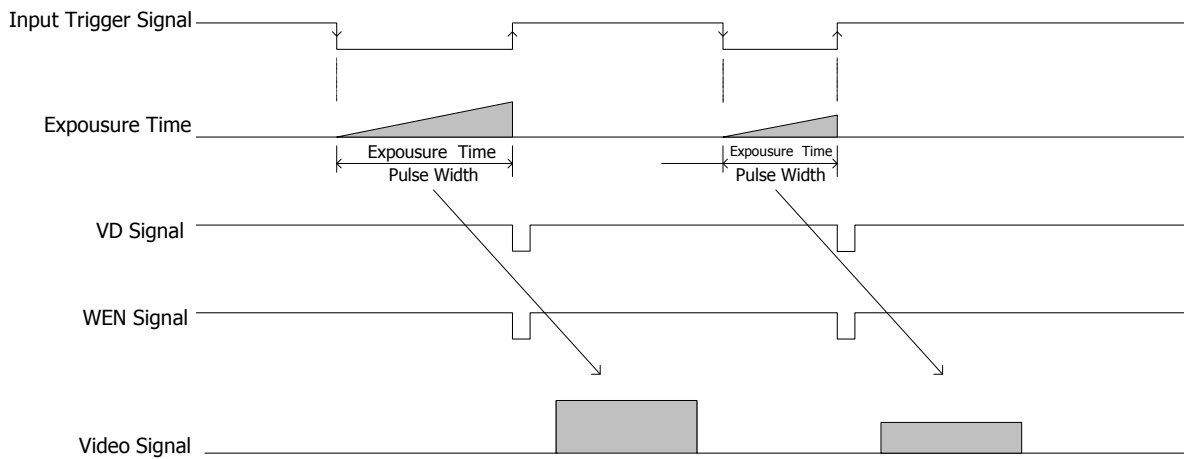

## 8. Remote Interface Function

Through RS-232C interface, the camera can be controlled by external PC.

### (1) The settings for RS-232C

Baud rate : 9600bps  
 Data : 8bit  
 Stop bit : 1bit  
 Parity : None  
 XOn/XOff : Not controlled

### (2) Control code

- The total control code is 14 bits, which conforms to ASCII code.
- The control code consists of camera No. process code, remote controller address, remote controller data, and CR. Execute Read/Write through PC, and the camera will reply the data.

1	2	3	4	5	6	7th Byte	8	9	10	11	12	13	14
Camera No.						Process code	Remote controller address			Remote controller data			CR
00000: Common to the all cameras. Individual camera No.						"R" Read mode	Please refer to the address table of 5. Function settings			000~255			0 Dh
						"W" Write mode							
						"C" Camera mode							

Camera No. shall consist of 6 bytes of characters/numeric strings.

Send the individual camera number code or common number code, "000000".

The reply data from the camera shall contain the registered number for that camera.

### Process code

Input any one of R, W, or C to the process code.

R (read mode) is to read the data of remote controller address.

Please be noted to set any dummy data (000~255) to 11<sup>th</sup> ~13<sup>th</sup>, since a command shall consists of 14 bytes.

W (write mode) is to write the data to the remote controller address.

Please be noted that the data cannot be saved into EEPROM of the camera.

(Reboot the camera, and the data is reset to the initial setting.)

To save the data into EEPROM, please refer to Clause 5. Function Settings.

C is the code to send the data back from the camera.

**Note: Do not set code C when sending the data from PC side.**

Remote controller address

**Note: Do not write the data into the address other than specified, since it may cause the damages or malfunction of the camera.**

Remote controller data

Set the decimal number (000~255) for the remote controller data. Please be noted to set any dummy data at read control mode.

CR

Be sure to input "CR" to confirm the end of the command.

※ When changing modes consecutively, 10ms after receiving reply from the camera should be waited to send the next command.

## 9. Initial Settings

Function	Address	Data
Gain	001	0: 0dB
E-Shutter	002	0: 1/30s(OFF)
White Balance	003	1: 3200K
Trigger Mode	004	0: Trigger Mode OFF
Trigger Polarity	005	1: Negative Input
SYNC ON/OFF	007	0: SYNC OFF
Manual Gain Control	008	Not specified
Manual Shutter Control	009&010	Not specified
Manual White Balance R-Gain Control	011	Not specified
Manual White Balance B-Gain Control	012	Not specified
Trigger Reset Mode	014	0: H-Synchronous Mode
75Ω Terminal	Rear Panel	SW(UP):75Ω Terminal ON
HD/VD IN or OUT	Rear Panel	SW(UP):HD/VD IN

10. CCD Optical Axis Accuracy

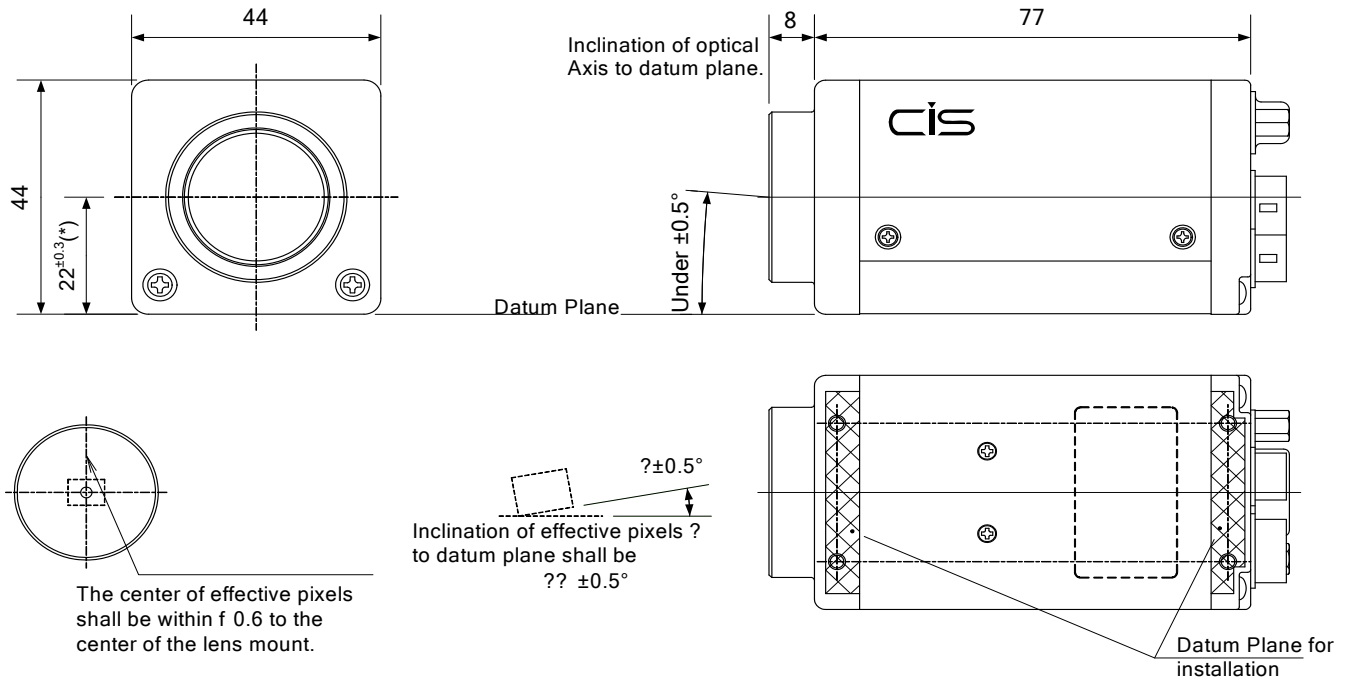

\*) Dimension from datum plane to the center of the lens mount

910-009-00-00

(Unit :mm)

11. Dimensions

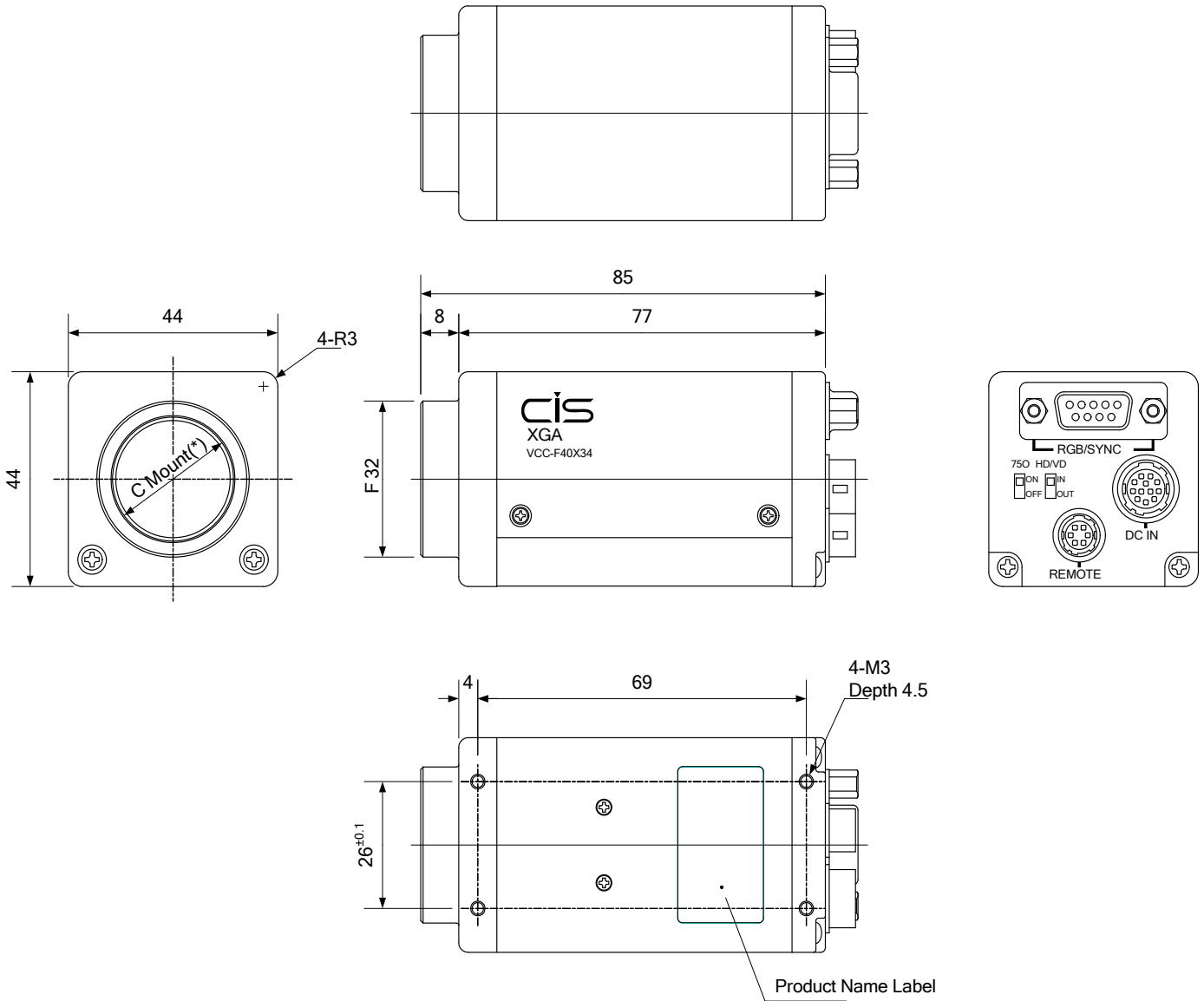

\*) C Mount screws comply with ANSI/ASME B1.1, 1-32UN (2B).

\*) Screw length from C mount lens surface shall be under 6mm. And, protruding portion shall be less than 10mm.

999-490-00-00  
(Unit :mm)

## 12. Cases for Indemnity (Limited Warranty)

We shall be exempted from taking responsibility and held harmless for damage or losses incurred by the user in the following cases.

- ✧ In case damage or losses are caused by fire, earthquake, or other acts of God, acts by third party, deliberate or accidental misuse by the user, or use under extreme operating conditions.
- ✧ In case indirect, additional, consequential damages (loss of business interests, suspension of business activities) are incurred as result of malfunction or non-function of the equipment, we shall be exempted from responsibility for such damages.
- ✧ In case damage or losses are caused by failure to observe the information contained in the instructions in this product specification & operation manual.
- ✧ In case damage or losses are caused by use contrary to the instructions in this product specification & operation manual.
- ✧ In case damage or losses are caused by malfunction or other problems resulting from use of equipment or software that is not specified.
- ✧ In case damage or losses are caused by repair or modification conducted by the customer or any unauthorized third party (such as an unauthorized service representative).
- ✧ Expenses we bear on this product shall be limited to the individual price of the product.

## 13. CCD Pixel Defect

After delivery, on the rare occasion, CCD pixel defects might be noted with time of usage of the products. The cause of the CCD pixel defects is the characteristic phenomenon of CCD itself and CIS shall be exempted from taking responsibility on it.

## 14. Product Support

When defects or malfunction of our products occur, and if you would like us to investigate on the cause and repair, please contact your distributors you purchased from to consult and coordinate.