



English

VISION:elite™
UXGA 3CCD Color
Camera Link Camera
VCC-F52U25CL

Product Specification
& Operational Manual

CIS Corporation

Table of Contents

| | PAGE |
|---|------|
| 1. Scope of Application..... | 3 |
| 2. Handling Precautions | 3 |
| 3. Product Outline | 5 |
| 4. Specification | 6 |
| 4.1. General Specification..... | 6 |
| 4.2. Camera Output Signal Specification..... | 8 |
| 4.3. CCD Spectral Response (Representative Value)..... | 9 |
| 4.3.1. CCD (ICX274AL) Spectral Response | 9 |
| 4.3.2. Prism Spectral Transmission Characteristics | 9 |
| 5. Function Settings..... | 10 |
| 6. External Connector Pin Assignment | 12 |
| 6.1. 12 pins Circular Connector HR10-10R-12PA (HIROSE)..... | 12 |
| 6.2. Camera Link Connector 12226-1100-00PL (SUMITOMO 3M)..... | 12 |
| 7. Timing Chart | 13 |
| 7.1. Horizontal Synchronous Signals Timing | 13 |
| 7.2. Vertical Synchronous Signals Timing | 13 |
| 7.3. Fixed Trigger Shutter Mode | 14 |
| 7.4. Pulse Width Trigger Shutter Mode..... | 15 |
| 8. Partial Scan Mode Details | 16 |
| 9. Remote Interface Function | 17 |
| 10. Initial Settings | 18 |
| 11. CCD Optical Axis Accuracy | 19 |
| 12. Dimensions | 20 |
| 13. Cases for Indemnity (Limited Warranty)..... | 21 |
| 14. CCD Pixel Defect..... | 21 |
| 15. Product Support | 21 |

1. Scope of Application

This is to describe VCC-F52U25CL, 3 CCD Color Camera Link Camera. All specifications contained herein are subject to change without prior notice. Reproduction in whole or in part is prohibited.

2. Handling Precautions

The camera must not be used for any nuclear equipments or aerospace equipments with which mechanical failure or malfunction could result in serious bodily injury or loss of human life.

Our warranty does not apply to damages or defects caused by irregular and/or abnormal use of the product.

Please make sure to use the camera under the temperature conditions specified below. Our warranty does not apply to damage or malfunction caused by ignoring these temperature conditions.

When the camera is used under ambient temperature over +30°C (86 degrees F), the temperature of upper part or side part of the camera body should be kept under +55°C (131 degrees F).

Please consider proper heat dissipation in your system installation.

These recommendations apply even when camera is used under performance guaranteed temperature and/or camera operation guaranteed temperature specified in our Specifications.

A temperature detecting sticker is enclosed for you to confirm and keep the camera body temperature under +55°C. Please put the sticker on the camera as shown below and make sure that the circle for 60 is white.

With a rise in temperature, color of the sticker goes to black. The circle for 60 must be kept white. (Please be noted that once the sticker color turns to black, it won't be back to white again.)

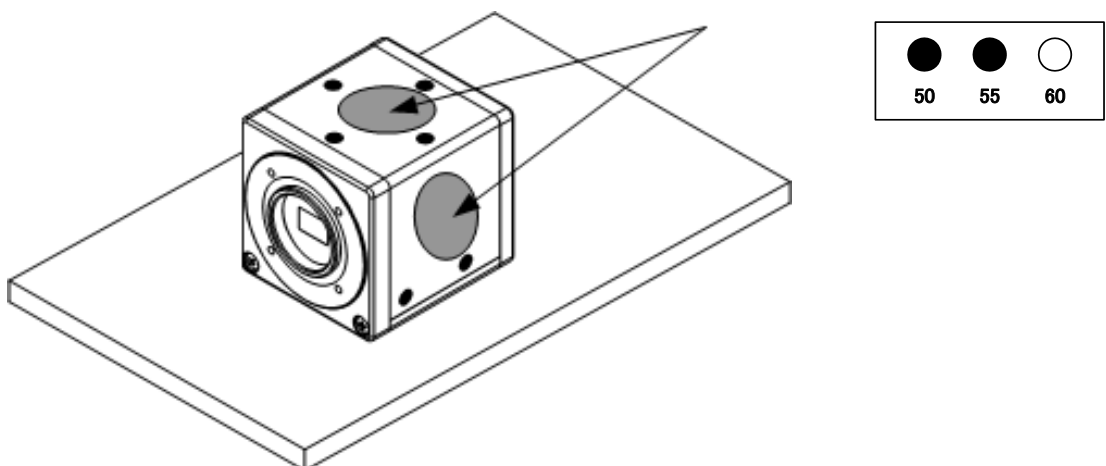

<Example> : Ambient temperature +45°C (113 degrees F), calm → Installed on an aluminum board. (120×200×5mm)

Please observe all warnings and cautions stated below.

Our warranty does not apply to damages or malfunctions caused by neglecting these precautions.

- Do not use or store the camera in the following extreme conditions:
 - Extremely dusty or humid places.
 - Extremely hot or cold places (operating temperature -5°C to $+45^{\circ}\text{C}$)
 - Close to generators of powerful electromagnetic radiation such as radio or TV transmitters.
 - Places subject to fluorescent light reflections.
 - Places subject to unstable (flickering, etc.) lighting conditions.
 - Places subject to strong vibration.
- Remove dust or dirt on the surface of the lens with a blower.
- Do not apply excessive force or static electricity that could damage the camera.
- Do not shoot direct images that are extremely bright (e.g., light source, sun, etc.), and when camera is not in use, put the lens cap on.
- Follow the instructions in Chapter 6, "External connector pin assignment" for connecting the camera. Improper connection may cause damages not only to the camera but also to the connected devices.
- Confirm the mutual ground potential carefully and then connect the camera to monitors or computers. AC leaks from the connected devices may cause damages or destroy the camera.
- Do not apply excessive voltage. (Use only the specified voltage.) Unstable or improper power supply voltage may cause damages or malfunction of the camera.
- The voltage ripple of camera power DC $+12\text{V}\pm 10\%$ shall be within $\pm 50\text{mV}$.
Improper power supply voltage may cause noises on the video signals.
- The rising time of camera power supply voltage shall be less than $+10\text{V}$, Max 60ms.
Please avoid noises like chattering when rising.

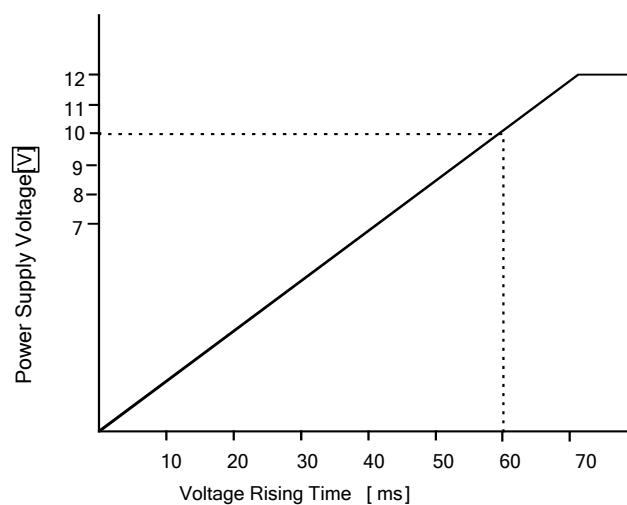

In case of abnormal operation, contact the distributor from whom you purchased the product.

3. Product Outline

VCC-F52U25CL is a camera link interfaced, 3CCD high-resolution industrial color video camera module utilizing a 1/1.8 type PS IT CCD. 2M pixels CCD image sensor with on-chip micro-lenses realizes high sensitivity and high resolution. Entire pixels can be read out within approx. 1/30s.

Features

- Shutter speed can be set from 1/30sec ~ 1/54,000sec by fixed switch shutter trigger, and 1/15sec ~ 1/8,000 by pulse width trigger.
- Frame rates are as follows both at normal operation and trigger operation.
 - 30 fps at full frame scan mode
 - 30fps ~ 60fps at partial scan mode
- Trigger operation is CLK synchronized V-Sync Reset type. Delay time between capturing the trigger pulse in the camera and starting exposure is approx. 0.96 μ sec (69CLK).
- At trigger operation, the new trigger input can be accepted even when outputting image signals for the prior trigger input. However, the new trigger input during the exposure shall be ignored. Please refer to the timing chart for the details.
- RGB 24bit/30bit are selectable.

Bundled Items

- Camera
- CIS Control Panel Software (For evaluation and demonstration purpose). ※
- ※ Please ask for the details or download it from our web.

4. Specification

4.1. General Specification

| Item | Specifications | | | |
|--|---|--|-----------------------|---------------------|
| (1) Pickup device | Device Type | 1/1.8 type Interline Transfer Color CCD, SONY ICX274AL | | |
| | Effective Pixel Number | 1628(H) × 1236(V) | | |
| | Unit Cell Size | 4.40μm(H) × 4.40μm(V) | | |
| | Chip Size | 8.50mm(H) × 6.80mm(V) | | |
| (2) Video output frequency | Pixel Clock | 72 MHz | | |
| | Horizontal Frequency | 37.5000kHz | Pixel Clock: 1920 CLK | |
| | Vertical Frequency | Full Frame Scan Mode | Scanning Lines | 1252 H 29.952 Hz |
| (3) Sync. system | Internal Sync. System | | | |
| (4) Video output standard | Camera Link (Base Configuration or Medium Configuration) | | | |
| (5) Resolution | 1200TV lines | | | |
| (6) Resolving power | RGB 24bit (Base Configuration) or RGB 30bit (Medium Configuration) selectable | | | |
| (7) Sensitivity | F5.6 2000lx (Shutter speed 1/30s(OFF), Gain 0dB) | | | |
| (8) Minimum illumination | F1.4 40lx (Shutter speed 1/30s(OFF), Gain +12dB) | | | |
| (9) Dust or stains in optical system | No dust or stain shall be detected on the testing screen with setting the camera aperture at F16. | | | |
| (10) Power requirements | DC+12V±10% (Max voltage not to exceed 15V.) | | | |
| (11) Power consumption | 5.5W (At DC+12V IN, normal mode, and full frame scan mode.) | | | |
| | 6.0W (At DC+12V IN, normal mode, and partial scan mode.) | | | |
| (12) Dimension | Refer to overall dimension drawing (Clause 12) H:55mm W:55mm D:60mm (excluding projection) | | | |
| (13) Mass | Approx. 215g | | | |
| (14) Lens mount | C mount (Refer to overall dimension drawing) | | | |
| (15) Optical axis accuracy | Refer to drawing for CCD Optical Axis Accuracy (Clause 11) | | | |
| (16) Gain variable range | 0dB~+12dB (Guaranteed range) | | | |
| (17) White balance adjustment guaranteed range | 2800K~9000K (Guaranteed range) | | | |
| (18) Shutter speed variable range | Fixed Shutter: 1/30(OFF), 1/60, 1/90, 1/120, 1/150, 1/200, 1/250, 1/500, 1/750, 1/1,000, 1/1,500, 1/2,500, 1/5,000, 1/10,000, 1/54,000s Pulse Width: 1/15~1/8,000s (Trigger input pulse width: 2,504H (max)~2H (min)) Manual Shutter: 1/30(Off)~1/54,000s | | | |
| (19) Trigger shutter mode | •Fixed Trigger Shutter Mode •Pulse Width Trigger Mode | | | |

| Item | Specifications | |
|-------------------------------|--|--|
| (20) Safety/Quality standards | UL: Conform to UL Standard including materials and others. RoHS: Conform to RoHS CE: Conform to EN55022:2006 (Class A) for Emission EN61000-6-2:2005 for Immunity FCC: To be applied Conform to FCC Class A digital Device This device complies with Part 15 of the FCC Rules. Operation is subject to the following two conditions: (1) this device may not cause harmful interference, and (2) this device must accept any interference received, including interference that may cause undesired operation. | |
| (21) Durability | Vibration | Acceleration : 21.6m/s ² (2.2G) |
| | | Frequency : 7~30 Hz (Frequency varies every 5 minutes. It shall be tested 15 minutes each for 3 directions.) |
| | | Direction : X,Y, and Z, 3 directions |
| | | Testing time : 15 min for each direction |
| Shock | No malfunction shall be occurred with 490m/s ² (50G) for ±X, ±Y, and ±Z, 6 directions. (without package) | |
| (22) Operation environment | Temperature | Performance guaranteed: 0°C~+40°C Operation guaranteed: -5°C~+45°C ※Specifications specified in this manual are guaranteed under performance guaranteed temperature. ※Camera functions can operate normally under operation guaranteed temperature. |
| | Humidity | RH 20~80% with no condensation |
| (23) Storage environment | Temperature | -25°C ~ +60°C |
| | Humidity | RH 20~80% with no condensation |

4.2. Camera Output Signal Specification

| Item | | Specifications |
|--------------------------|----------------------------------|--|
| (1) Video output data | Video out | 1624(H) × 1224(V) At Full Frame Scan Mode |
| (2) Sync. Signal I/O | HD(LVAL) :6 pin | 12pins circular connector (TTL Output) |
| | VD(FVAL) :7 pin | |
| | WEN(DVAL) :10pin | |
| | EXP(Exposure) :9 pin | |
| (2) Sync. Signal I/O | LVAL | Camera Link Output (LVDS) |
| | FVAL | |
| | DVAL | |
| | SP(Exposure) | |
| (3) Trigger input | Polarity | Positive/Negative Selectable |
| | Pulse width | Over 2H (min) ~Under 2504HD (max) |
| | Trigger Input :11pin CC1 | 12pins circular connector (TTL Input) Camera Link Input (LVDS) |
| (4) Serial communication | SerTC (Serial to camera) | Camera Link Input (LVDS) |
| | SerTFG (Serial to frame grabber) | Camera Link Output (LVDS) |
| (5) Video output signal | White Clip Level | At Digital 8bit : FFh |
| | Setup Level | At Digital 8bit : 08h |
| | Dark Shading | : Under 08h±04h At Digital 8bit for both horizontal and vertical. (Conditions: Gain 0dB) |

※ 5 seconds shall be waited after turning on power to get proper camera operation.

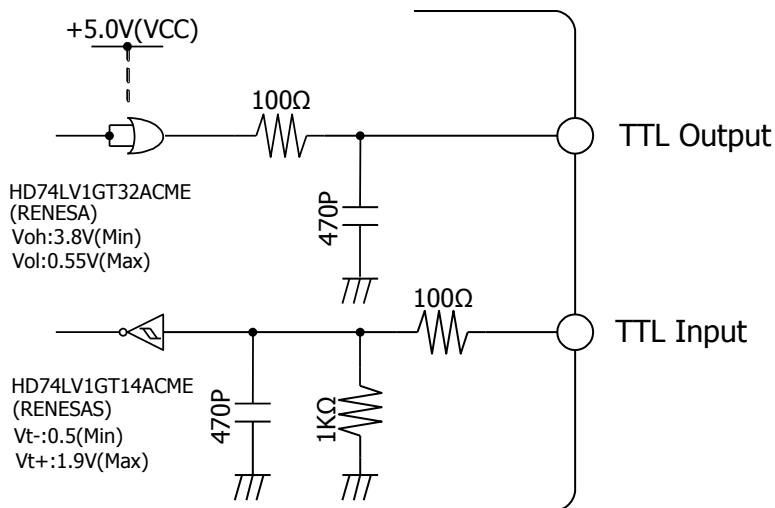

12pins circular connector at rear, GPIO Interface

4.3. CCD Spectral Response (Representative Value)

4.3.1. CCD (ICX274AL) Spectral Response

※ Lens characteristics, IR cut filter, and luminous source characteristics are not considered.

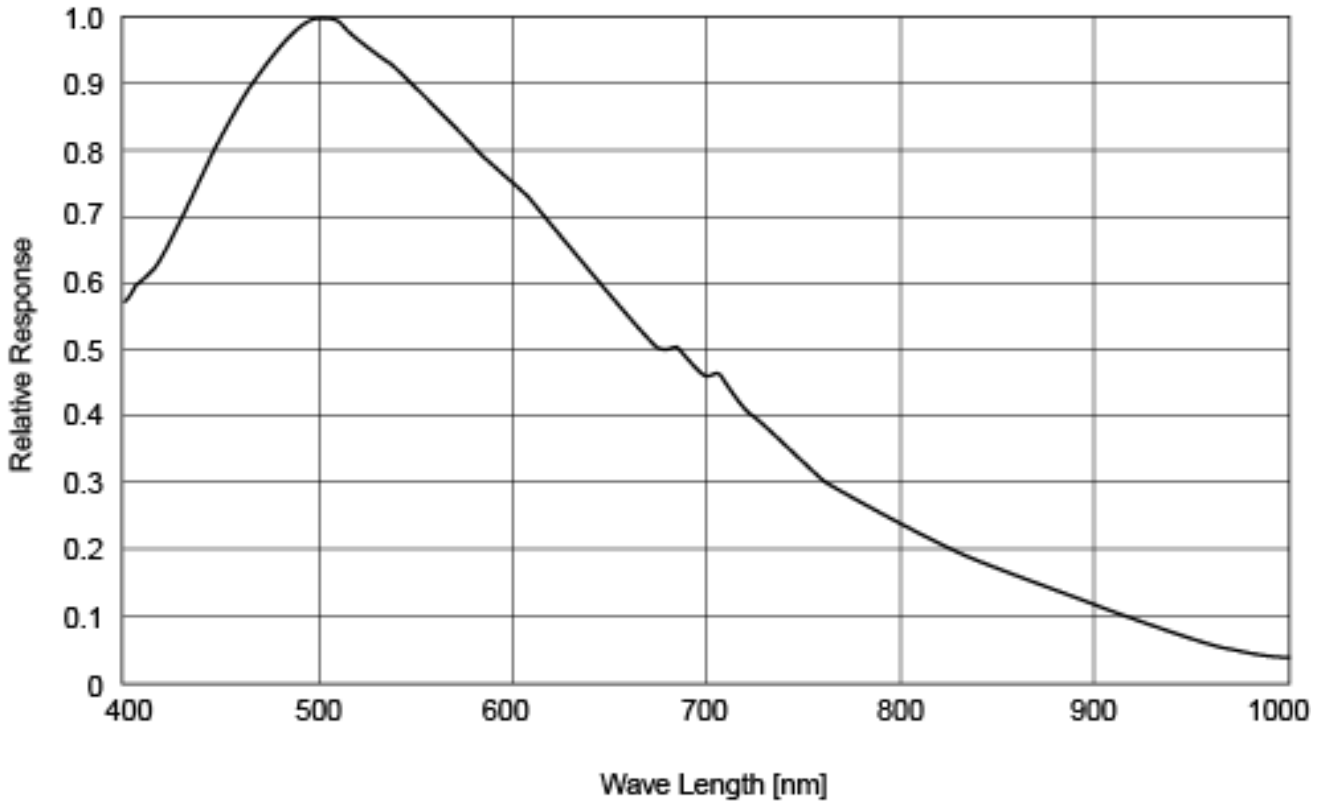

4.3.2. Prism Spectral Transmission Characteristics

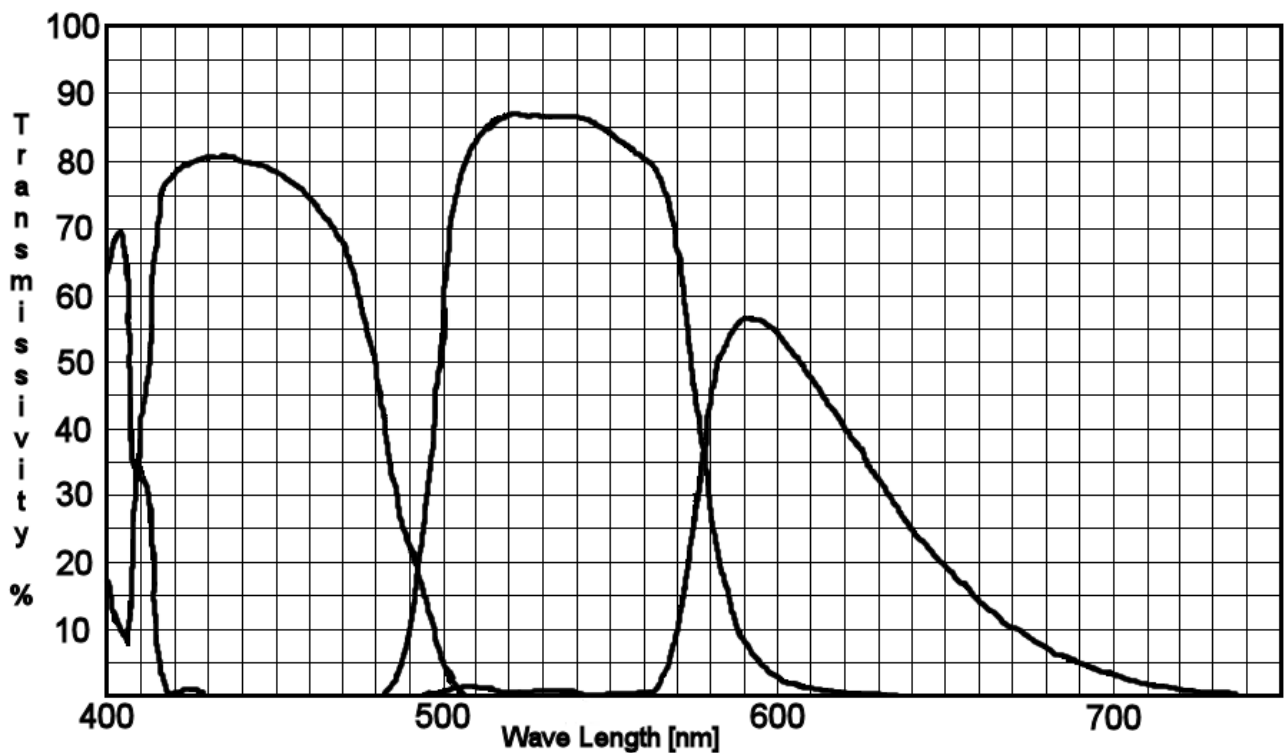

5. Function Settings

Camera functions can be set with serial data communications.

| Functions | Address | Data |
|--|---------|--|
| Gain | 001 | 0: 0 dB : Analog Fixed Gain |
| | | 1: + 3 dB : Analog Fixed Gain |
| | | 2: + 6 dB : Analog Fixed Gain |
| | | 3: + 12 dB : Analog Fixed Gain |
| | | 4: Manual Gain : over 0dB~+12dB (Refer to address 030&031.) |
| E-Shutter | 002 | 0: 1/30s (Off) |
| | | 1: 1/30s (Off) |
| | | 2: 1/60s |
| | | 3: 1/90s |
| | | 4: 1/120s |
| | | 5: 1/150s |
| | | 6: 1/200s |
| | | 7: 1/250s |
| | | 8: 1/500s |
| | | 9: 1/750s |
| | | 10: 1/1000s |
| | | 11: 1/1500s |
| | | 12: 1/2500s |
| | | 13: 1/5000s |
| | | 14: 1/10000s |
| | | 15: 1/54000s |
| 16: Manual Shutter (Refer to address 009 & 010.) | | |
| White Balance | 003 | 0: THUR |
| | | 1: 3200K |
| | | 2: THUR |
| | | 3: THUR |
| | | 4: Manual White Balance : Adjustment guaranteed range: over 2800K ~9000K (Refer to address 156&157, and 158&159) |
| Trigger Mode | 004 | 0: Normal Shutter Mode (Trigger Off) |
| | | 1: Fixed Trigger Shutter Mode (Shutter speed can be set with address 002.) |
| | | 2: Pulse Width Trigger Shutter Mode (Shutter speed can be set with trigger pulse width.) |
| Manual Shutter Control | 009&010 | 0~1251: 1/30s(Off) ~ 1/54000s |
| | | ※Set the data of address 002 to 016. |
| | | Address 009 MSB and address 010 LSB makes 16bit in total. |
| | | Shutter speed = (1251 - (009&010)) × 26.27μ s + 18.53μ s Max Data = 1251 |
| Trigger Polarity | 011 | 0: Positive Input |
| | | 1: Negative Input |
| Trigger Input | 012 | 0: Camera Link (CC1) Input |
| | | 1: 12pin Connector(11pin) Input |

| Functions | Address | Data |
|-----------------------------|---------|--|
| Output Data Select | 013 | 0: RGB 24bit Output Data |
| | | 1: RGB 30bit Output Data |
| Gamma Mode | 014 | 0: Gamma Off (1.0) |
| | | 1: Gamma On (Option) |
| Partial Scan Mode | 015 | 0: Full Frame Scan Mode |
| | | 1: Partial Scan Mode |
| Partial Scan Start Position | 016&017 | 0~407: ※Set the data of address 015 to 001. |
| | | Address 016 MSB and address 017 LSB makes 16bit in total. |
| | | Start Position:3 H/step Min Data:0(0 H) / Max Data:407(1221 H) |
| | | Start Position(016&017) + Effective Line(019&020) <= 407 |
| Partial Scan Effective Line | 019&020 | 0~407: ※Set the data of address 015 to 001. |
| | | Address 019 MSB and address 020 LSB makes 16bit in total. |
| | | Effective Line:3 H/step Min Data:0(3 H) / Max Data:407(1224 H) |
| | | Start Position(016&017) + Effective Line(019&020) <= 407 |
| Partial Scan Total Line | 021&022 | 0~1251: Read Only |
| | | Total line numbers at Partial Scan Mode or at Full Frame Scan Mode minus 1H will be set. |
| Manual Analog Gain | 030&031 | 0~512: 0:0dB ~ 512: over +12dB (Log Linear) ※Set the data of address 001 to 004. |
| Digital Gain G | 128&129 | 256~512: 256:×1(0dB) ~ 512:×2(+6dB) |
| Manual White Balance R | 156&157 | 256~1024: 256:×1(0dB) ~ 1024:×4(+12dB) ※Set the data of address 003 to 004. |
| Manual White Balance B | 158&159 | 256~1024: 256:×1(0dB) ~ 1024:×4(+12dB) ※Set the data of address 003 to 004. |
| Data Save | 255 | Input 083 or 053 to save the data to EEP-ROM. |

※ Note: When setting the data with 2 Byte, High Byte shall be set first, then Low Byte to the next.
The camera rewrites the internal resister when receiving Low Byte.

6. External Connector Pin Assignment

6.1. 12 pins Circular Connector HR10-10R-12PA (HIROSE)

| Pin No. | |
|---------|----------------------|
| 1 | GND |
| 2 | Power In DC +12V |
| 3 | GND |
| 4 | NC |
| 5 | GND |
| 6 | HD(LVAL) Output |
| 7 | VD(FVAL) Output |
| 8 | GND |
| 9 | EXP(Exposure) Output |
| 10 | WEN(DVAL) Output |
| 11 | Trigger Input |
| 12 | GND |

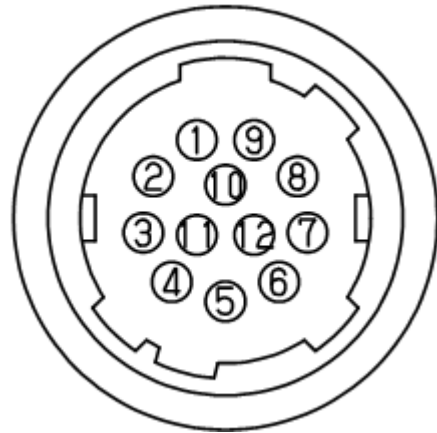

6.2. Camera Link Connector 12226-1100-00PL (SUMITOMO 3M)

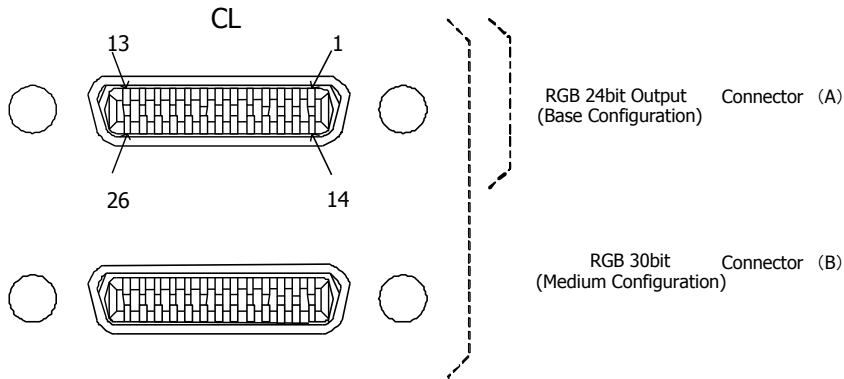

Connector (A)

| Pin No. | | Pin No. | |
|---------|------------------------|---------|------------------------|
| 1 | GND | 14 | GND |
| 2 | X0- | 15 | X0+ |
| 3 | X1- | 16 | X1+ |
| 4 | X2- | 17 | X2+ |
| 5 | Xclk- | 18 | Xclk+ |
| 6 | X3- | 19 | X3+ |
| 7 | SerTC+ | 20 | SerTC- |
| 8 | SerTFG- | 21 | SerTFG+ |
| 9 | CC1- (Trigger IN -) | 22 | CC1+ (Trigger IN +) |
| 10 | NC (CC2+) | 23 | NC (CC2-) |
| 11 | NC (CC3-) | 24 | NC (CC3+) |
| 12 | NC (CC4+) | 25 | NC (CC4-) |
| 13 | GND | 26 | GND |

Connector (B)

| Pin No. | | Pin No. | |
|---------|-------|---------|------------|
| 1 | NC | 14 | GND |
| 2 | Y0- | 15 | Y0+ |
| 3 | Y1- | 16 | Y1+ |
| 4 | Y2- | 17 | Y2+ |
| 5 | Yclk- | 18 | Yclk+ |
| 6 | Y3- | 19 | Y3+ |
| 7 | 100Ω | 20 | Terminated |
| 8 | NC | 21 | NC |
| 9 | NC | 22 | NC |
| 10 | NC | 23 | NC |
| 11 | NC | 24 | NC |
| 12 | NC | 25 | NC |
| 13 | GND | 26 | NC |

7. Timing Chart

7.1. Horizontal Synchronous Signals Timing

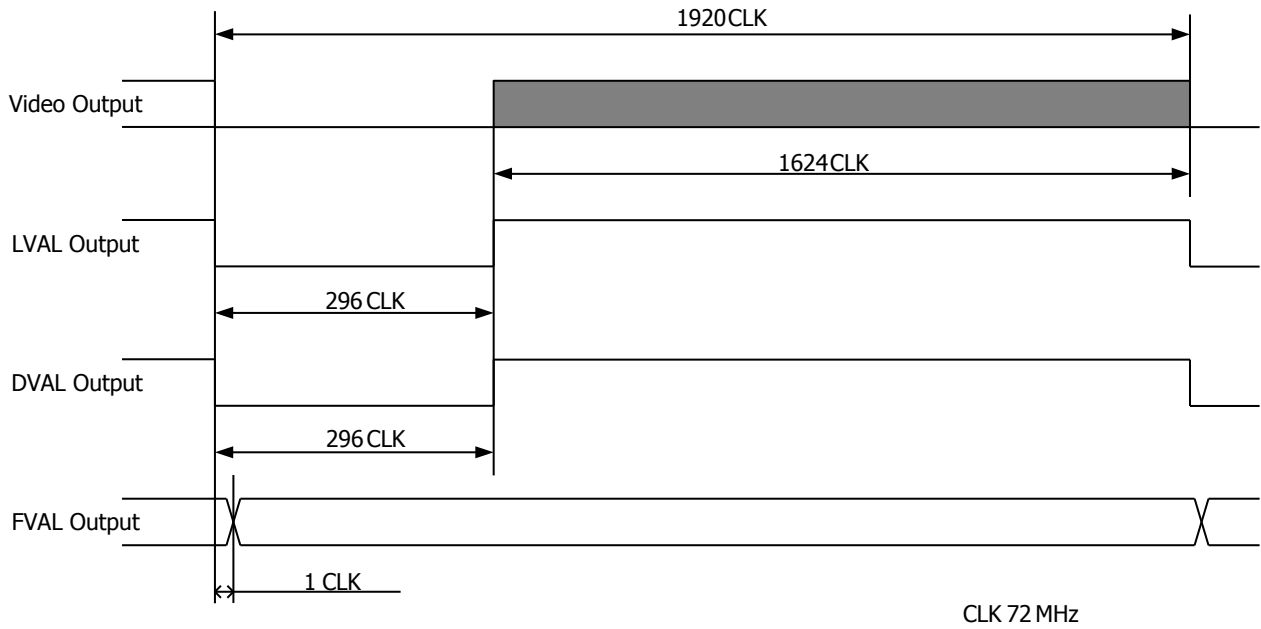

7.2. Vertical Synchronous Signals Timing

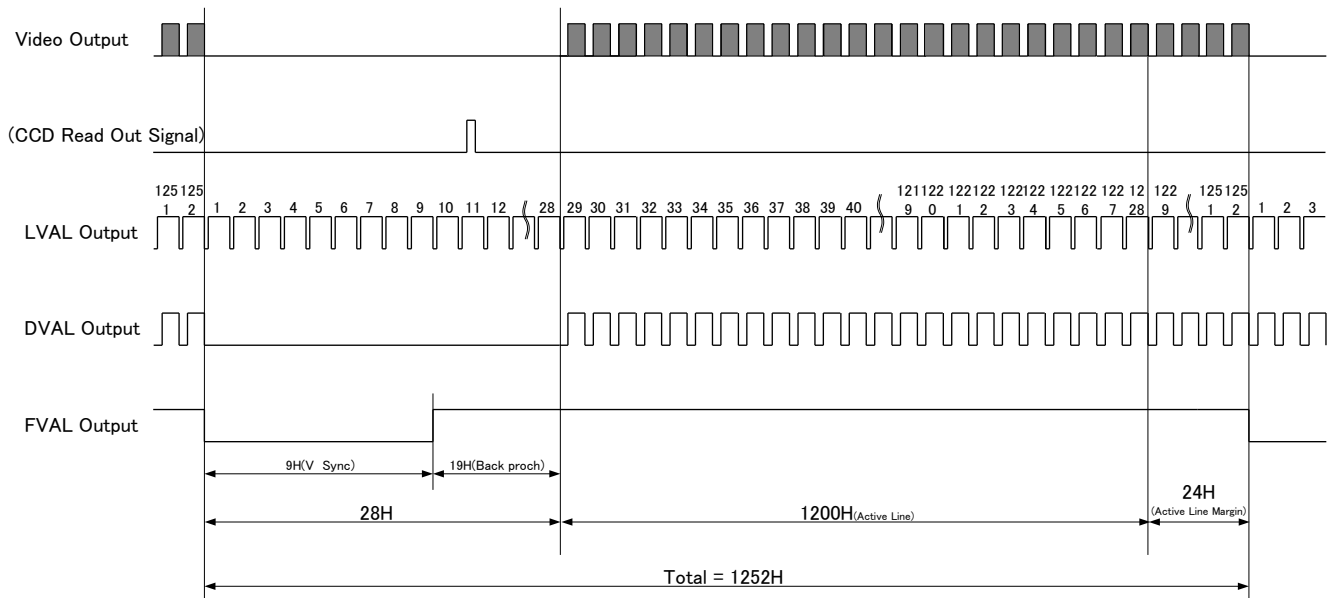

7.3. Fixed Trigger Shutter Mode

- Trigger operation is CLK sync, V-Sync Reset.
Delay time, from detecting the trigger edge to starting exposure, is $0.96\mu s$.
- Trigger input can be accepted even when the camera is outputting video signals.
However, a shutter timing, to start the next video output before completion of transferring video output for the prior signals, cannot be worked. To input trigger signals when the camera is outputting video signals for the prior signals, it shall be synchronized with the down edge of camera LVAL output.
- Trigger input during the execution of exposure (exposure time) shall be ignored.
(Refer to the "G" below.)

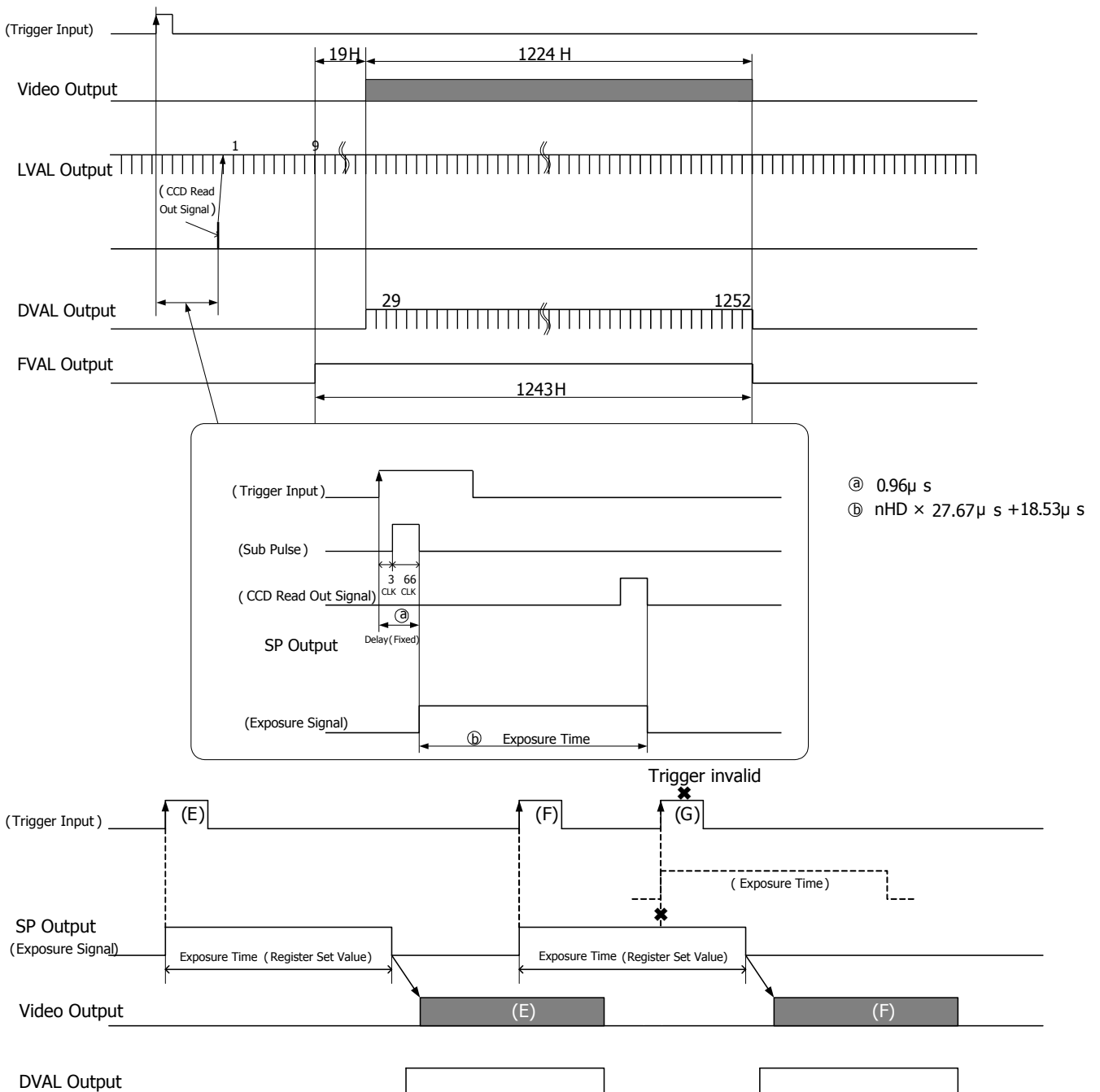

7.4. Pulse Width Trigger Shutter Mode

- Trigger operation is CLK sync, V-Sync Reset.

Delay time, from detecting the trigger edge to starting exposure, is $0.96\mu s$.

Delay time, from detecting the trigger edge to completing exposure, is $19.49\mu s$.

- Trigger input can be accepted even when the camera is outputting video signals.

However, a shutter timing, to start the next video output before completion of transferring video output for the prior signals, cannot be worked. Please refer to the "C" below.

To input trigger signals when the camera is outputting video signals for the prior signals, it shall be synchronized with the down edge of camera LVAL output.

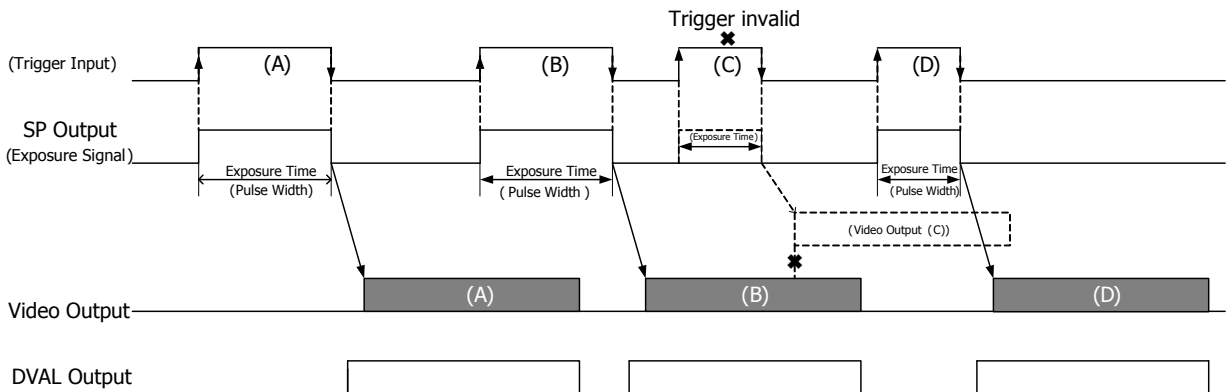
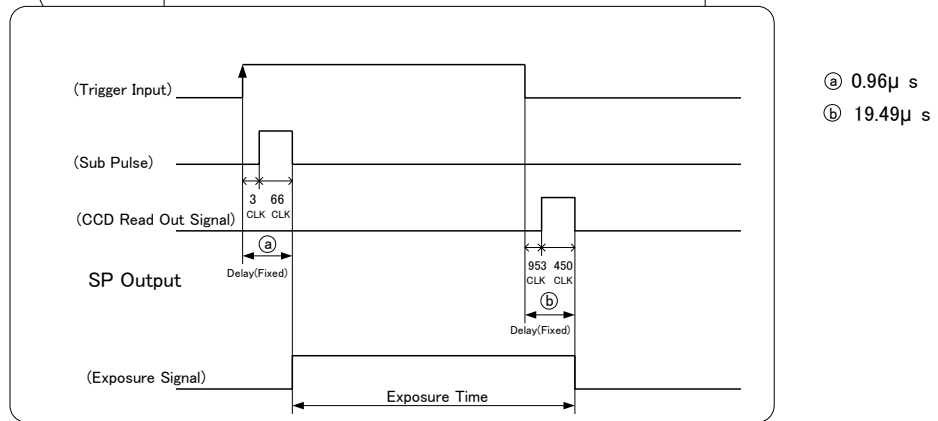
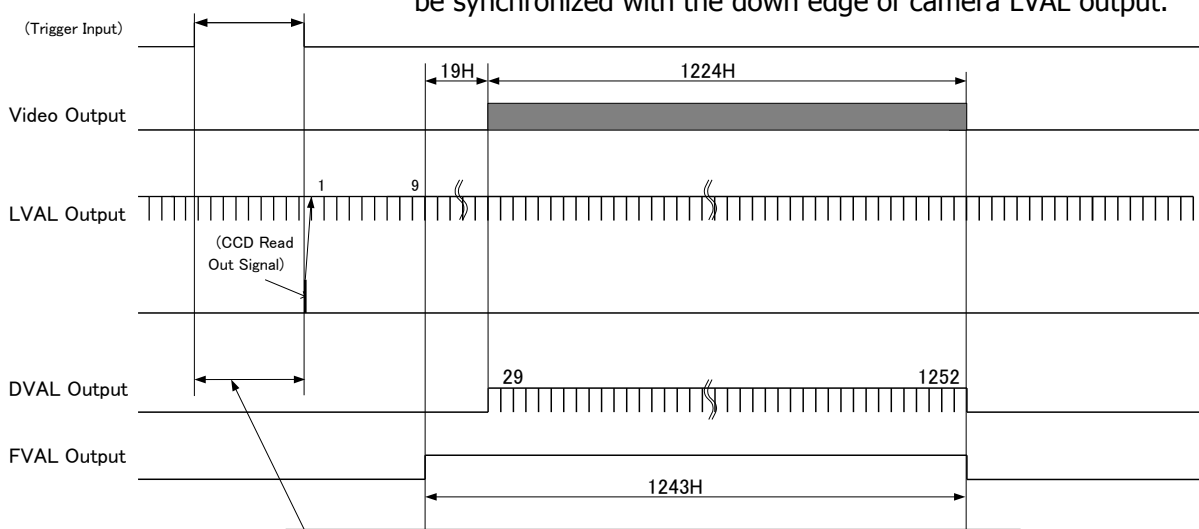

8. Partial Scan Mode Details

Capturing start position and capturing width can be set by 3H via LAN.

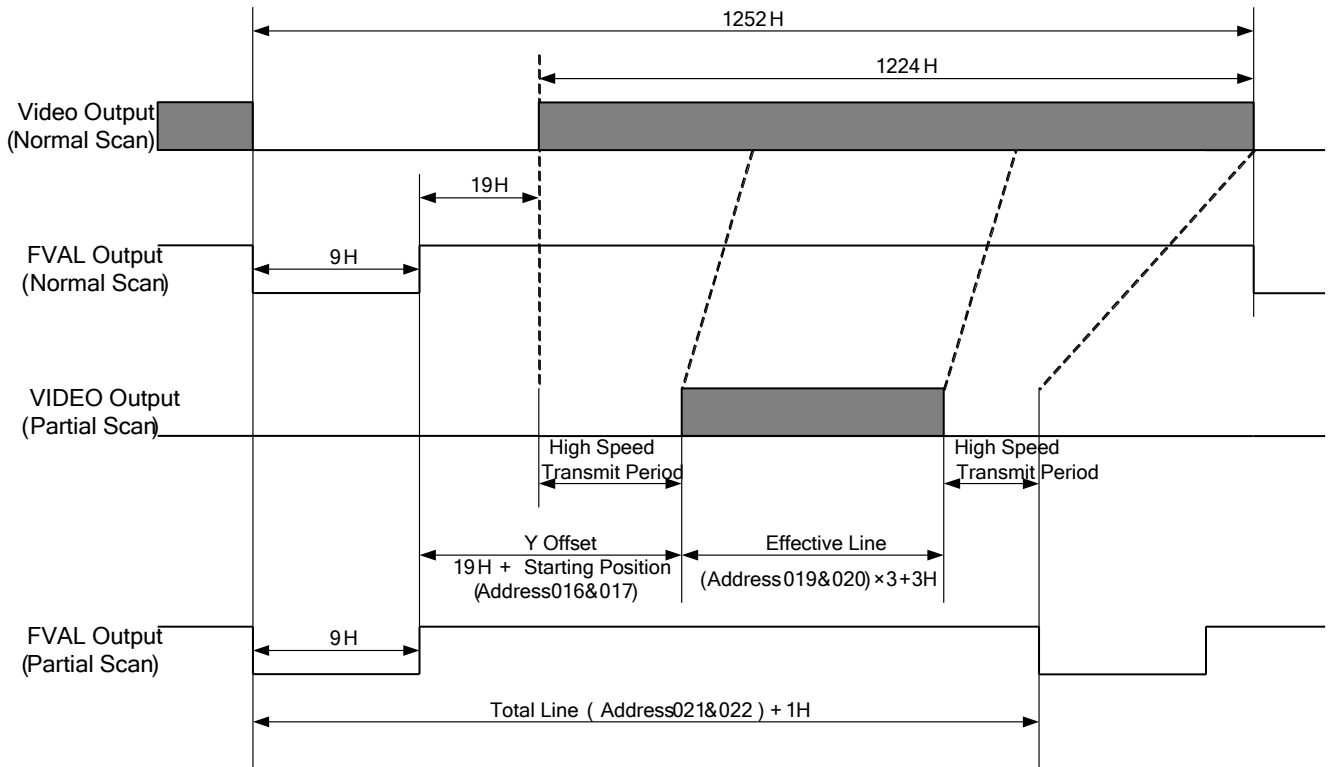

Reading out position register (Address 016&017) : 0(0 H)~407(1221 H) 3 H/step

Effective line register (Address 019&020) : 0(3 H)~407(1224 H) 3 H/step

Total line register (Address 021&022) : 435 H + (Effective Line register × 2) + 2 (Read Only)

Note: Reading out position and effective lines shall meet the following condition.

Reading out position register + Effective line register = < 407

Otherwise, the value, **407 – reading out position register**, will be set to the effective line register.

<Example 1> Conditions: Reading out position register (Address 016 & 017) = 000

| Effective line register (Address 019&020) | Effective Lines | Total Line register + 1H | Frame rate |
|--|-----------------|-----------------------------|------------|
| 0 | 3 H | 438 H | 86 fps |
| . | . | . | . |
| 159 | 480 H | 756 H | 50 fps |
| . | . | . | . |
| 255 | 768 H | 948 H | 40 fps |
| . | . | . | . |
| 341 | 1026 H | 1120 H | 33 fps |
| . | . | . | . |
| 407 | 1224 | 1252 H | 30 fps |

9. Remote Interface Function

Through serial port of camera link connector, the camera can be controlled.

(1) The settings for RS-232C

Baud rate : 9600bps
 Data : 8bit
 Stop bit : 1bit
 Parity : None
 XOn/XOff : Not controlled

(2) Control code

- The total control code is 14 bits, which conforms to ASCII code.
- The control code consists of camera No. process code, remote controller address, remote controller data, and CR. Execute Read/Write through PC, and the camera will reply the data.

| 1 | 2 | 3 | 4 | 5 | 6 | 7th Byte | 8 | 9 | 10 | 11 | 12 | 13 | 14 |
|----------------------------|---|---|---|---|---|--|---|---|----|------------------------|----|----|------|
| Camera No. | | | | | | Process code | Remote controller address | | | Remote controller data | | | CR |
| 000000: fixed | | | | | | "R" Read mode "W" Write mode "C" Camera mode | Please refer to the address table of Section 5., Function Settings. | | | 000~255 | | | 0 Dh |
| 00EEEE: 4digits error code | | | | | | "X" error response | 0 | 0 | 0 | 0 | 0 | 0 | |

Camera No. is fixed with 6 bite numerical strings, "000000".

Process code

Input any one of R, W, or C to the process code.

R (read mode) is to read the data of remote controller address.

Please be noted to set any dummy data (000~255) to 11th ~13th, since a command shall consists of 14 bytes.

W (write mode) is to write the data to the remote controller address.

Please be noted that the data cannot be saved into EEPROM of the camera.

(Reboot the camera, and the data is reset to the initial setting.)

To save the data into EEPROM, please refer to Section 5., Function Settings.

C is the code to send the data back from the camera.

Note: Do not set code C when sending the data from PC side.

X is the code to respond when the camera side detects an error.

Error details can be checked with 4 digits, 3rd to 6th bytes.

- 0101 Address value error
- 0102 Command error
- 0103 Data value error
- 0104 Data length error (over 14 byte)

Remote controller address

Note: Do not write the data into the address other than specified, since it may cause the damages or malfunction of the camera.

Remote controller data

Set the decimal number (000~255) for the remote controller data. Please be noted to set any dummy data at read control mode.

CR

Be sure to input "CR" to confirm the end of the command.

※ Note: When setting the data with 2 Byte, High Byte shall be set first, then Low Byte to the next. The camera rewrites the internal register when receiving Low Byte.

10. Initial Settings

| Function | Address | Data |
|-------------------------|---------|---|
| Gain | 001 | 0: 0 dB |
| E-Shutter | 002 | 0: 1/30s(Off) |
| White Balance | 003 | 1: 3200K |
| Trigger Mode | 004 | 0: Normal Trigger Mode (Trigger Mode Off) |
| Trigger Polarity | 011 | 0: Positive Input |
| Trigger Input | 012 | 0: Camera Link (CC1) Input |
| Output Data Select | 013 | 0: 24bit RGB Output Data |
| Gamma Mode | 014 | 0: Gamma OFF (1.0) |
| Partial Scan Mode | 015 | 0: Full Frame Scan Mode |
| Partial Scan Total Line | 021&022 | 1251: Read Only |

11. CCD Optical Axis Accuracy

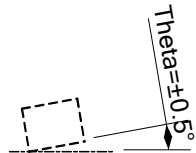
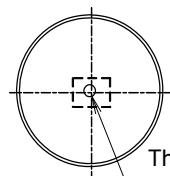
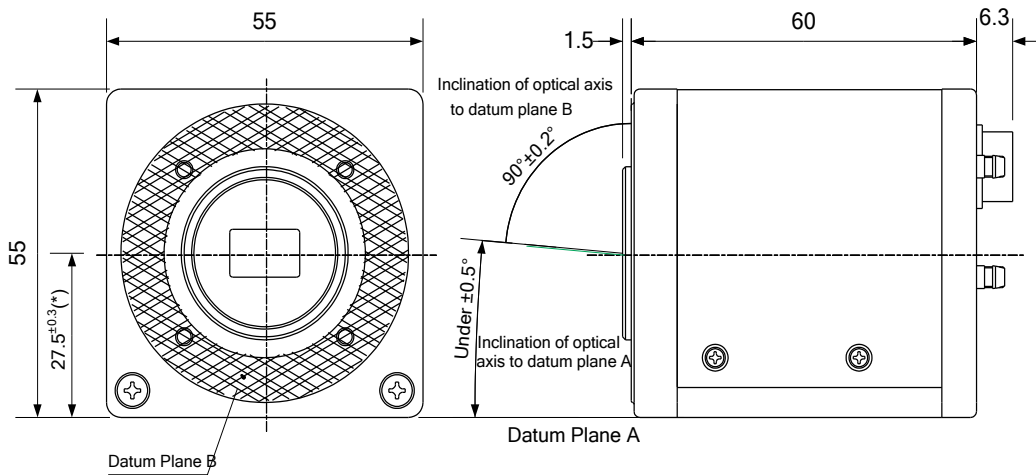

Inclination of effective pixels theta to datum plane A.
Theta shall be under ± 0.5°

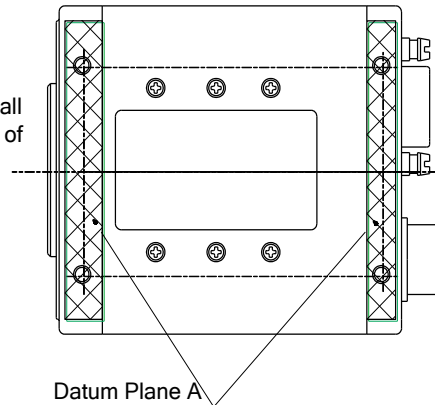

*)Dimensions from datum plane A to the center of the lens mount

910-010-00-00
(Unit:mm)

12. Dimensions

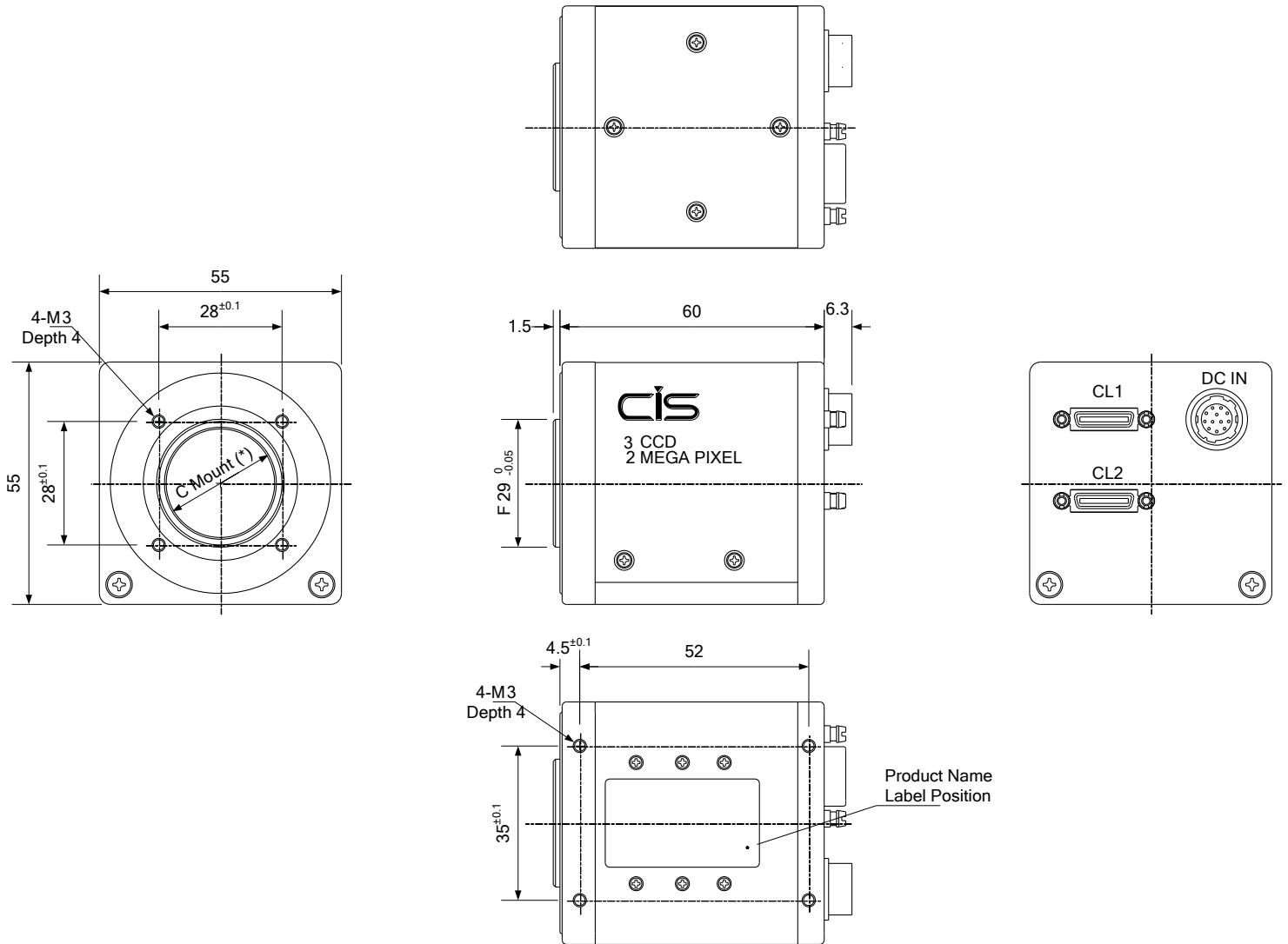

*) C Mount screws comply with ANSI/ASME B1.1, 1-32U (2B).

*) Screw length from C mount lens surface shall be under 4.5mm. And protruding portion shall be less than 4.5mm.

999-502-00-02

(Unit :mm)

13. Cases for Indemnity (Limited Warranty)

We shall be exempted from taking responsibility and held harmless for damage or losses incurred by the user in the following cases.

- ✧ In case damage or losses are caused by fire, earthquake, or other acts of God, acts by third party, deliberate or accidental misuse by the user, or use under extreme operating conditions.
- ✧ In case indirect, additional, consequential damages (loss of business interests, suspension of business activities) are incurred as result of malfunction or non-function of the equipment, we shall be exempted from responsibility for such damages.
- ✧ In case damage or losses are caused by failure to observe the information contained in the instructions in this product specification & operation manual.
- ✧ In case damage or losses are caused by use contrary to the instructions in this product specification & operation manual.
- ✧ In case damage or losses are caused by malfunction or other problems resulting from use of equipment or software that is not specified.
- ✧ In case damage or losses are caused by repair or modification conducted by the customer or any unauthorized third party (such as an unauthorized service representative).
- ✧ Expenses we bear on this product shall be limited to the individual price of the product.

14. CCD Pixel Defect

CIS compensates the noticeable CCD pixel defects found at the shipping inspection prior to our shipment. On very rare occasions, however, CCD pixel defects might be noted with time of usage of the products. Cause of the CCD pixel defects is the characteristic phenomenon of CCD itself and CIS is exempted from taking any responsibilities for them.

Should you have any questions on CCD pixel defects compensation, please contact us.

15. Product Support

When defects or malfunction of our products occur, and if you would like us to investigate on the cause and repair, please contact your distributors you purchased from to consult and coordinate.